

# Methods of Controlling Machine Access

**Schaedler**  
*yesco*

ALLEN-BRADLEY • ROCKWELL SOFTWARE

**Rockwell**  
**Automation**

# Machine Guarding - Overview

---

- Guarding personnel in or around hazardous machinery or equipment can be accomplished by several means and a complete guarding system is usually comprised of several safety devices.
- This class addresses guarding techniques using optical safety devices for protecting personnel from machine or equipment hazards without providing a physical barrier.
- There may be local standards or regulations which are required to be adhered to when applying personnel detection devices.
- In general, a risk assessment of each machine should be completed, this can be a formal machine guarding risk assessment which addresses every aspect of a machine's operation or a very basic assessment of the machine hazards which an operator will be exposed to.
- This class discussion relates to methods of preventing access to point of operation (POC) hazards as well as providing detection of personnel around the perimeter of equipment or work cells (PAC)

# Safety Distance

---

- There are a number of safety distance formulas depending upon which standard or regulation is followed but all rely on a hand speed or approach constant times the total stop time of all devices in stop circuit.
  - Some also include a depth penetration factor which is an adder due to how far a person's finger, hand, arm, etc will penetrate the sensing field before being detected

Example - ANSI Formula:  $D_s = [ K \times (T_s + T_c + T_r) + D_{pf}$

- $D_s$  = minimum safe distance between safeguarding device and the hazard
- $K$  = speed of body or parts of body
- $T_s$  = worst stopping time of the machine and equipment
- $T_c$  = worst stopping time of the control system.
- $T_r$  = response time of the safeguarding device
- $D_{pf}$  = Maximum travel towards the hazard before a stop is signaled

# Selecting the Proper Height

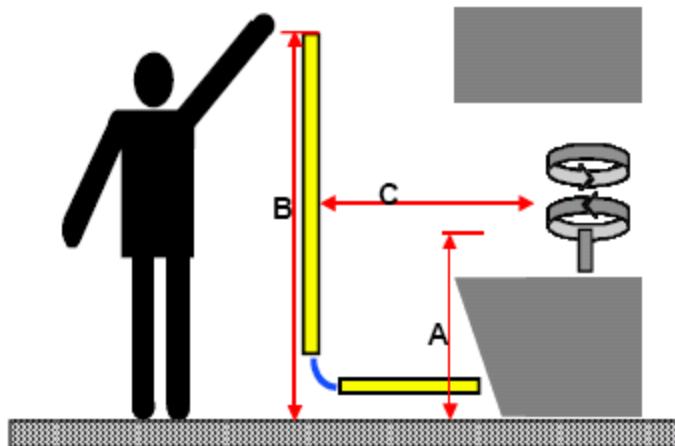

- **Safety Distance (S) must be calculated prior to determining protected Height (H)**
  - Only access to hazard should be through the sensing field of the safety device
- Once the proper safety distance is calculated, sizing of light curtain is determined
- Reaching over, under or around the safety light curtain to access the hazard must be prevented
  - Typically hard guarding is used to prevent access to the hazard from the side, top and bottom access can be with hard guards or additional safety light curtains

# Types of Light Curtain mounting according to EN999

Vertical

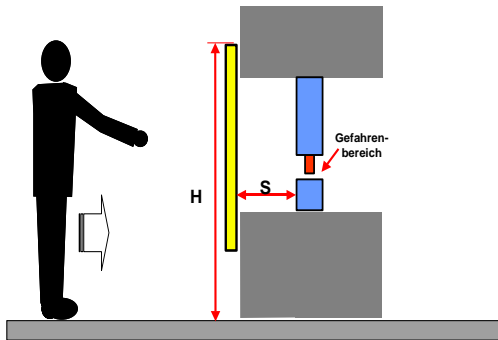

Angled

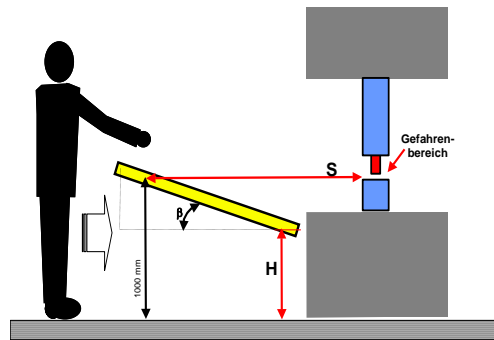

Horizontal

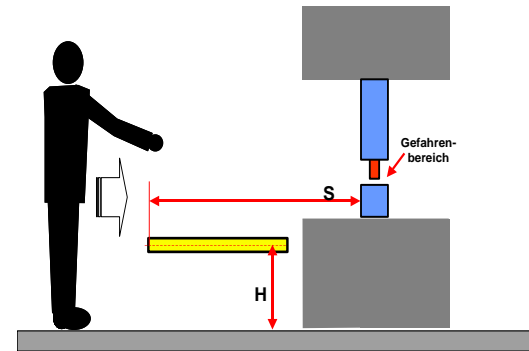

# Proper Light Curtain Application

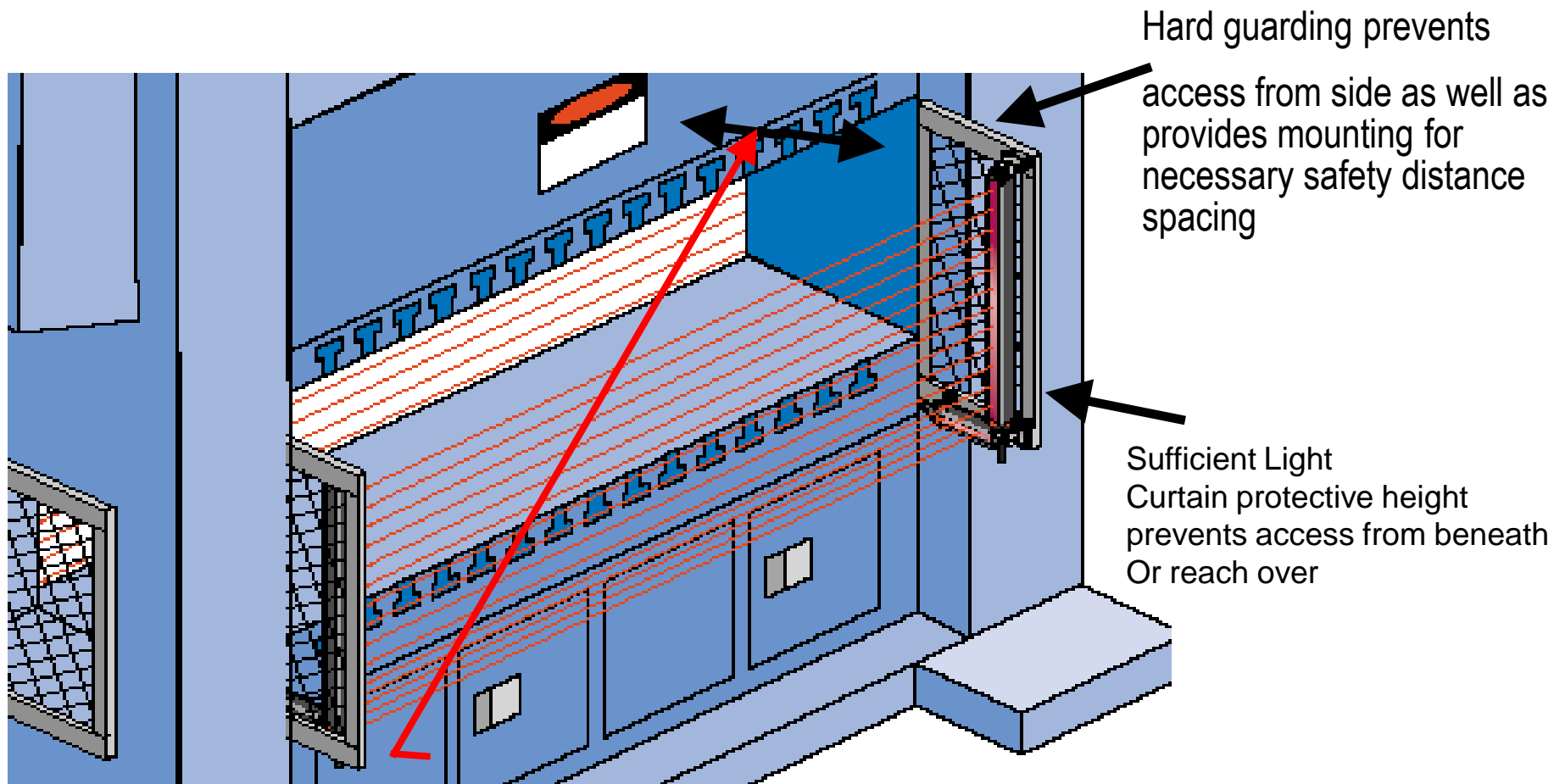

Sufficient safety distance from point of operation hazard

# Machine Guarding

---

WHY??





# Machine Safety Cycle

## STEP 5

### MAINTAIN & IMPROVE The SAFETY SYSTEM

- Maintain the safety system at optimal levels
- Improve the safety system as new knowledge is gained



## STEP 1

### RISK OR HAZARD ASSESSMENT

- Identify the Hazards and Sources of Failure on a machine or process



## MACHINE SAFETY LIFE CYCLE

## STEP 4

### SAFETY SYSTEM VALIDATION

- Verify that the Safety System meets the requirements
- Train personnel to safely operate and maintain machine



## STEP 3

### SAFETY SYSTEM IMPLEMENTATION

- Design hazards out of the system
- Implement the Safety System



## STEP 2

### SAFETY SYSTEM REQUIREMENTS

- Determine how much risk is tolerable
- Define methods to reduce risk to tolerable levels



# HOW ABOUT WARNING SIGNS?

---



# Machine Guarding - Overview

---

- **Once a Risk assessment has been carried out, it is necessary to identify the equipment hazards and then determine the machine's characteristics in order that presence sensing devices may be applied to the machinery.**
  - **Able to stop anywhere in stroke or cycle**
  - **Consistent and repeatable stop time required**
  - **Ejection of materials can not be prevented with presence sensing devices**
  - **Heat or radiation hazard**
  - **Environmental influences; oil mist, splashing water, temperature, corrosive gases, etc**
- **Once a presence sensing device is determined to be the appropriate means of detecting personnel from the machine's hazard(s) it is necessary to determine the type(s) of application, POC, PAC, AAC and select the appropriate device(s) to be used to detect the approach of a person or a part of the person.**
- **This presence sensing device must be positioned at a distance from the hazard to assure sufficient time for the hazardous motion to cease.**

# Safety Light Curtain Application Types

## Point of Operation (POC)

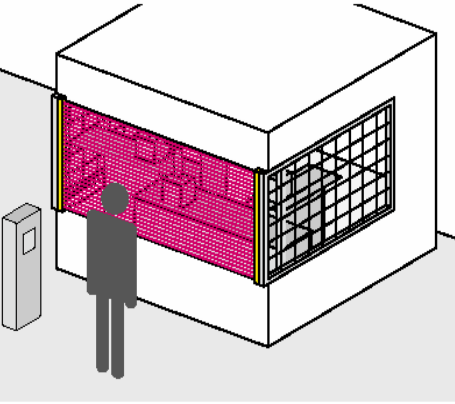

- Allows frequent and easy access to point of operation hazard
- May Automatically Reset When Operator Removes Hand Arm from Hazard
- Type 4 for high risk, severe injury applications possible
- Type 2 for low risk, first aid type injuries possible
- Safety Light Curtain Resolutions;
  - 14mm Finger Protection
  - 30mm Hand Protection

## Perimeter Access (PAC)

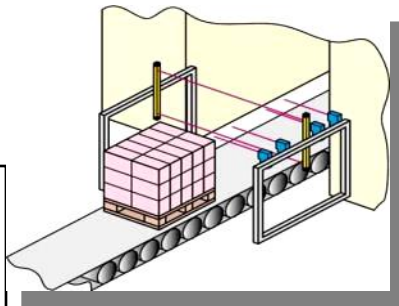
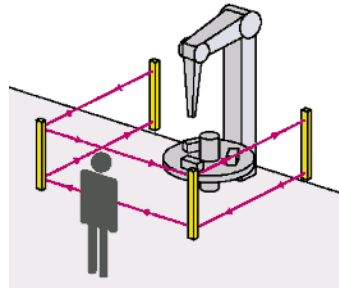

- Opto electronic fence with multiple sided protection or whole body access detection
- Allows easy Perimeter Access.
- Must be Manually reset, external to work cell
- Typically 2 or 3 beams for Whole Body detection

## Area Access (AAC)

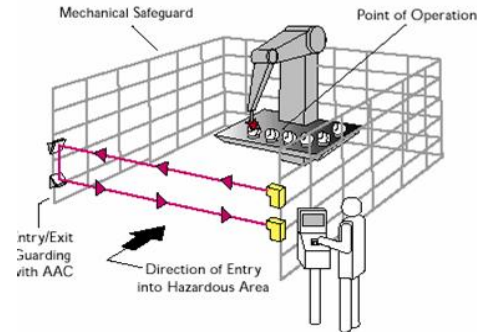

- Allows easy Access.
- Must be Manually reset, external to work cell
- Single Beam
- (18M) or (70M) range
- Whole Body Detection

## Safety Laser Scanner

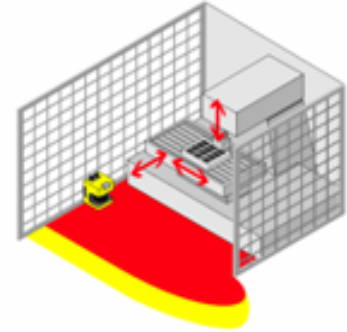

- Allows easy Access.
- Warning and safety field
- Configurable resolutions

# Application Example

Presence Sensing devices allow frequent and easy Access to hazardous areas.

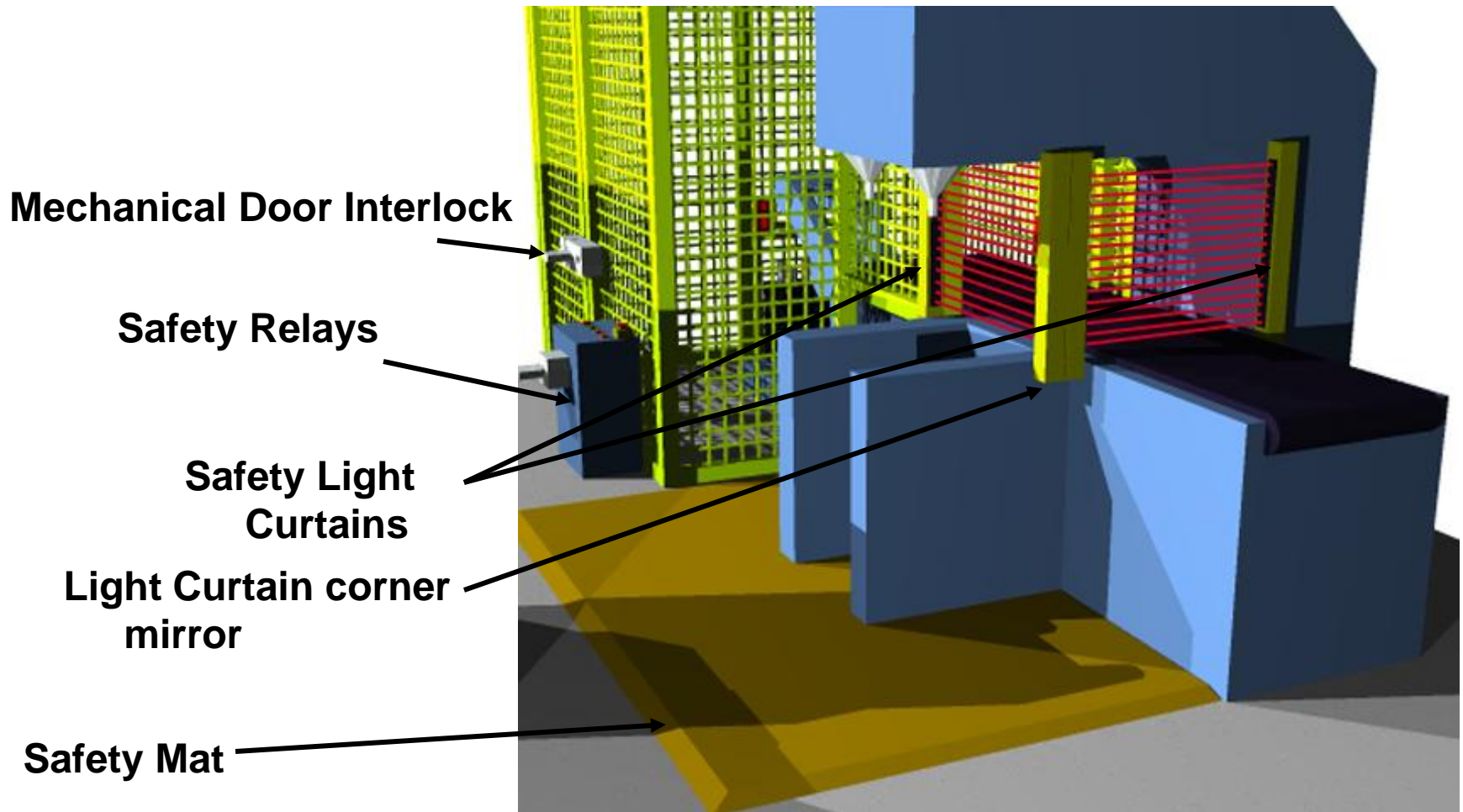

# Rockwell Automation Safety Light Curtains

## POC Light Curtains Type 4



GuardShield

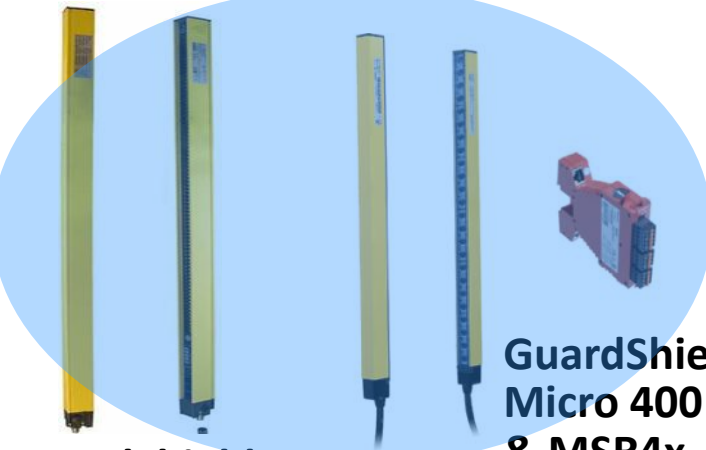

GuardShield Safe 4

GuardShield Micro 400 & MSR4x

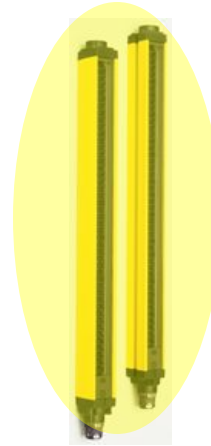

SafeShield

## Laser Scanner



SafeZone Multizone

## POC Light Curtains Type 2



GuardShield Type 2

GuardShield Safe 2

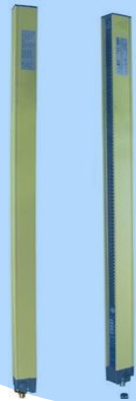

## PAC Light Curtains Type 4



GuardShield Safe 4 PAC

GuardShield Type 4 PAC



## AAC



# Application device selection flow chart

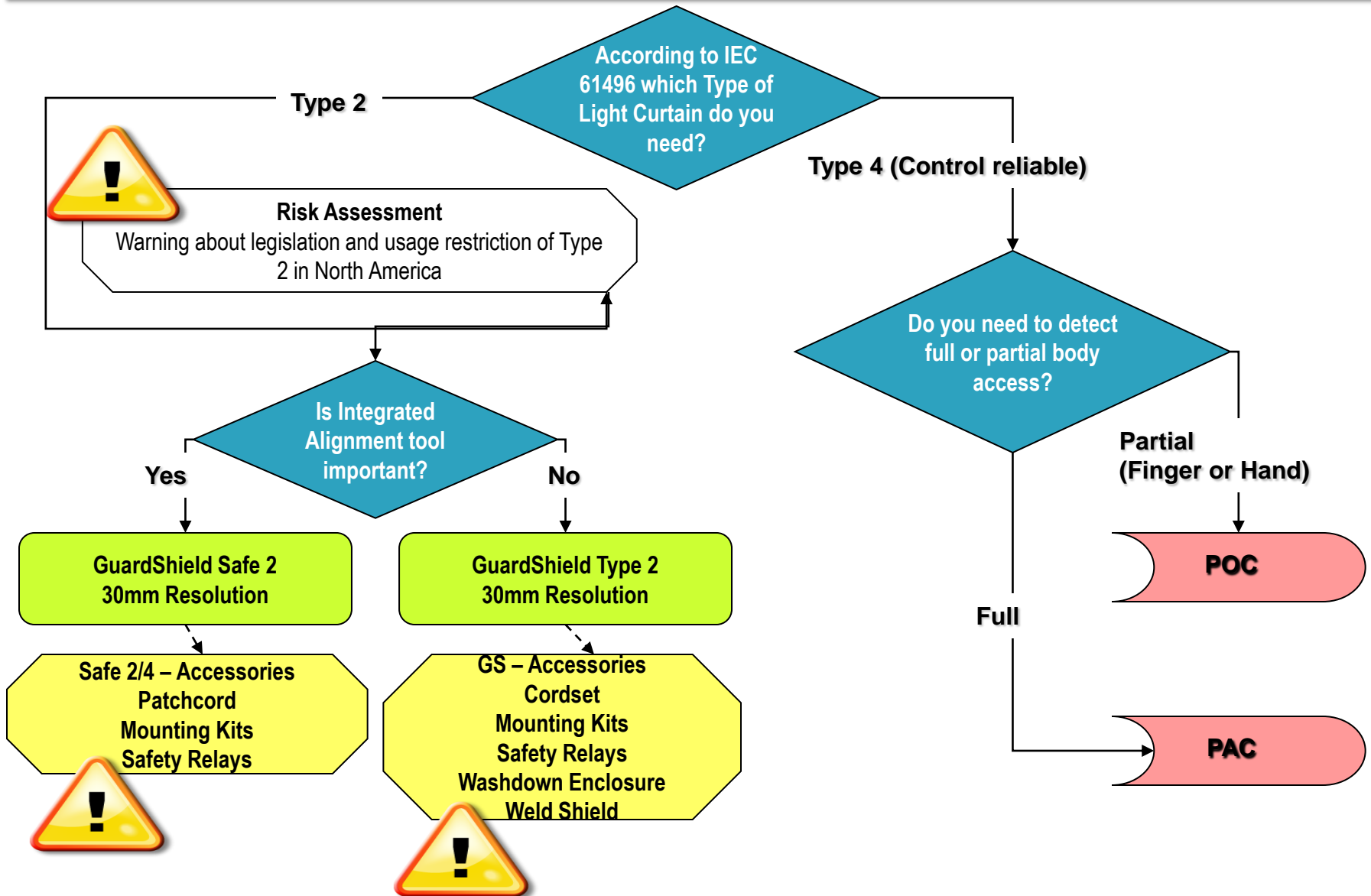

# POC Light Curtain Selection

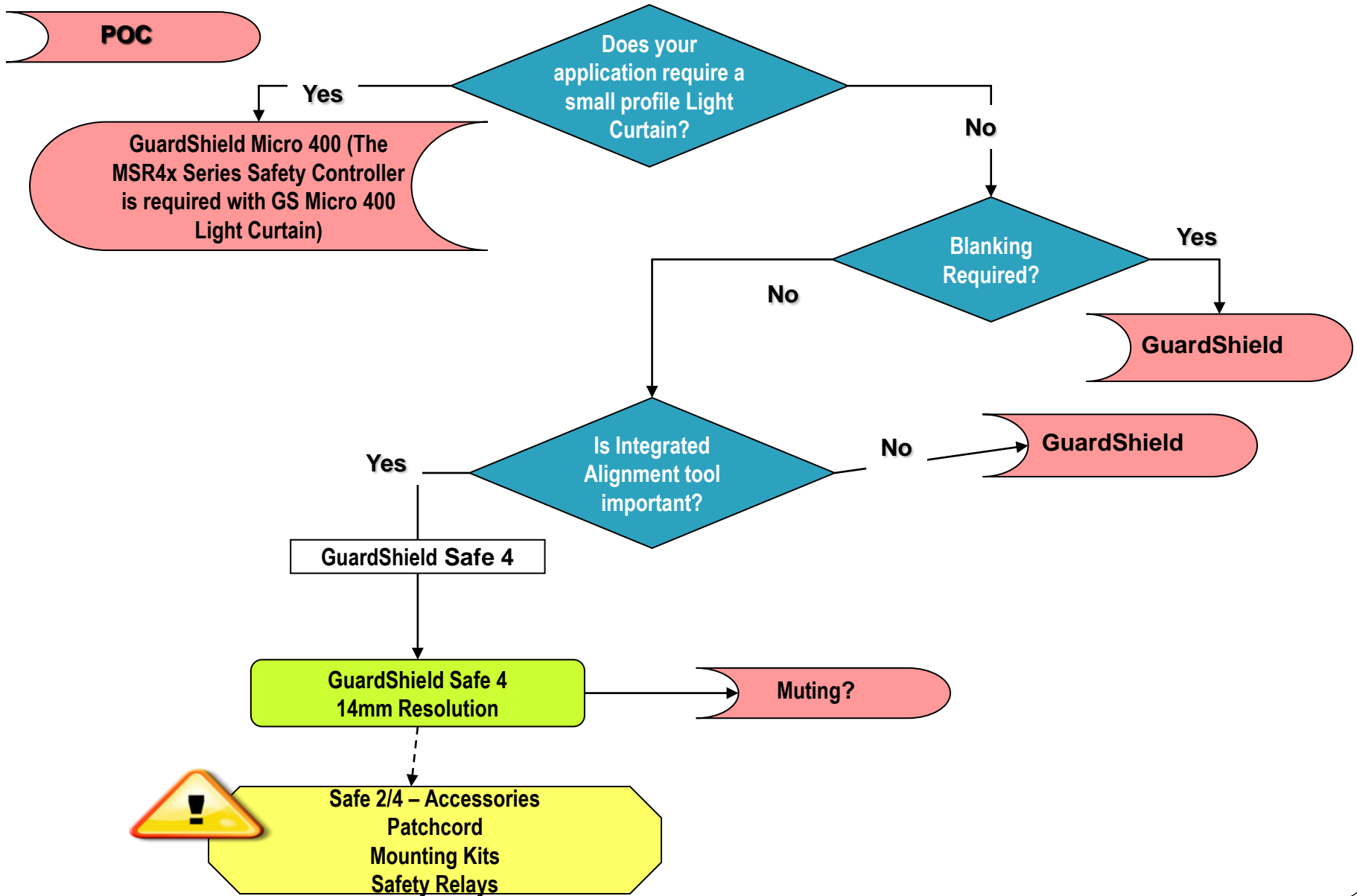

# GuardShield Micro 400 Selection Chart

GuardShield Micro 400 (The MSR4x Series Safety Controller is required with GS Micro 400 Light Curtain)

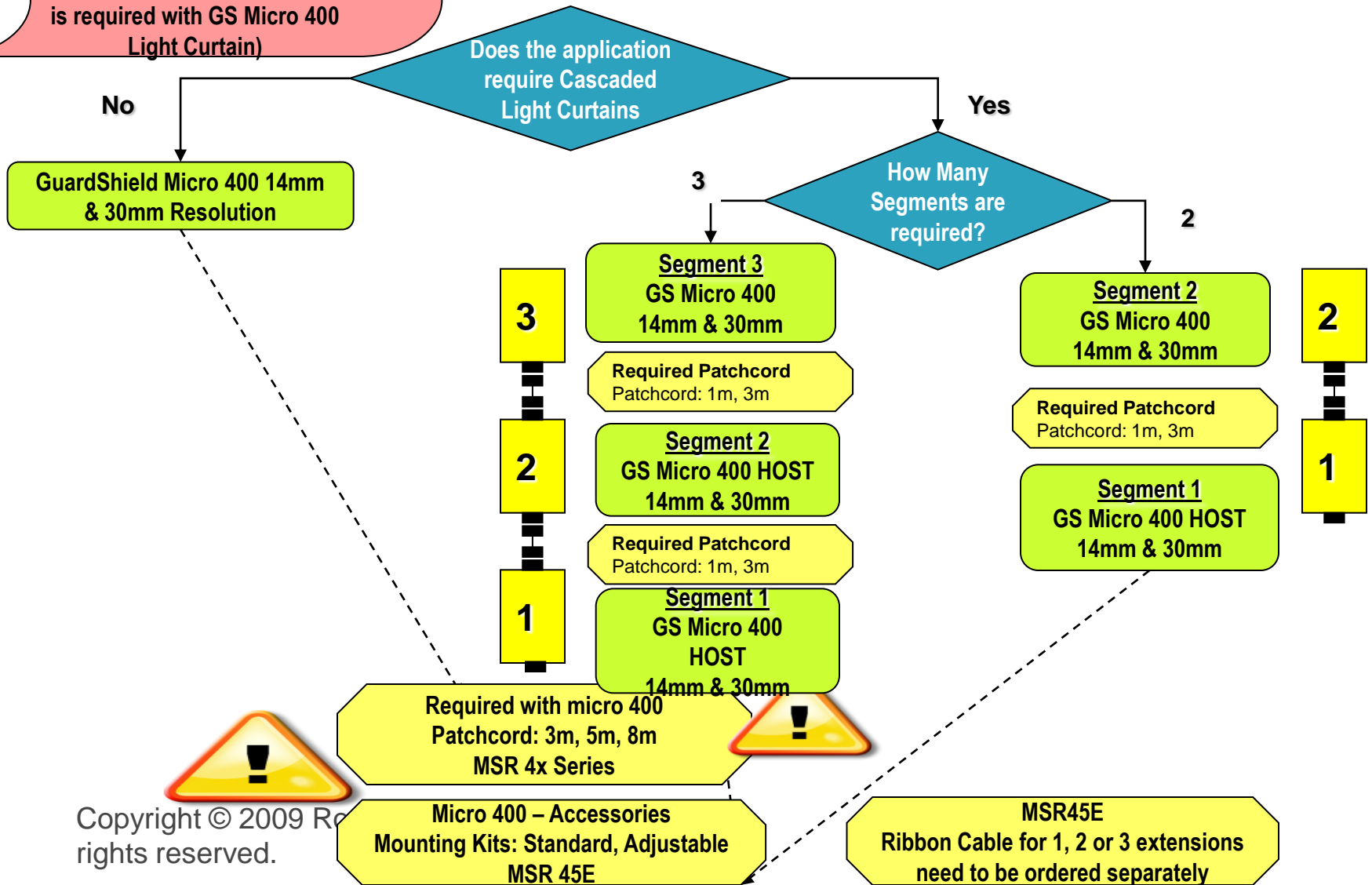

# GuardShield Selection Chart

## GuardShield

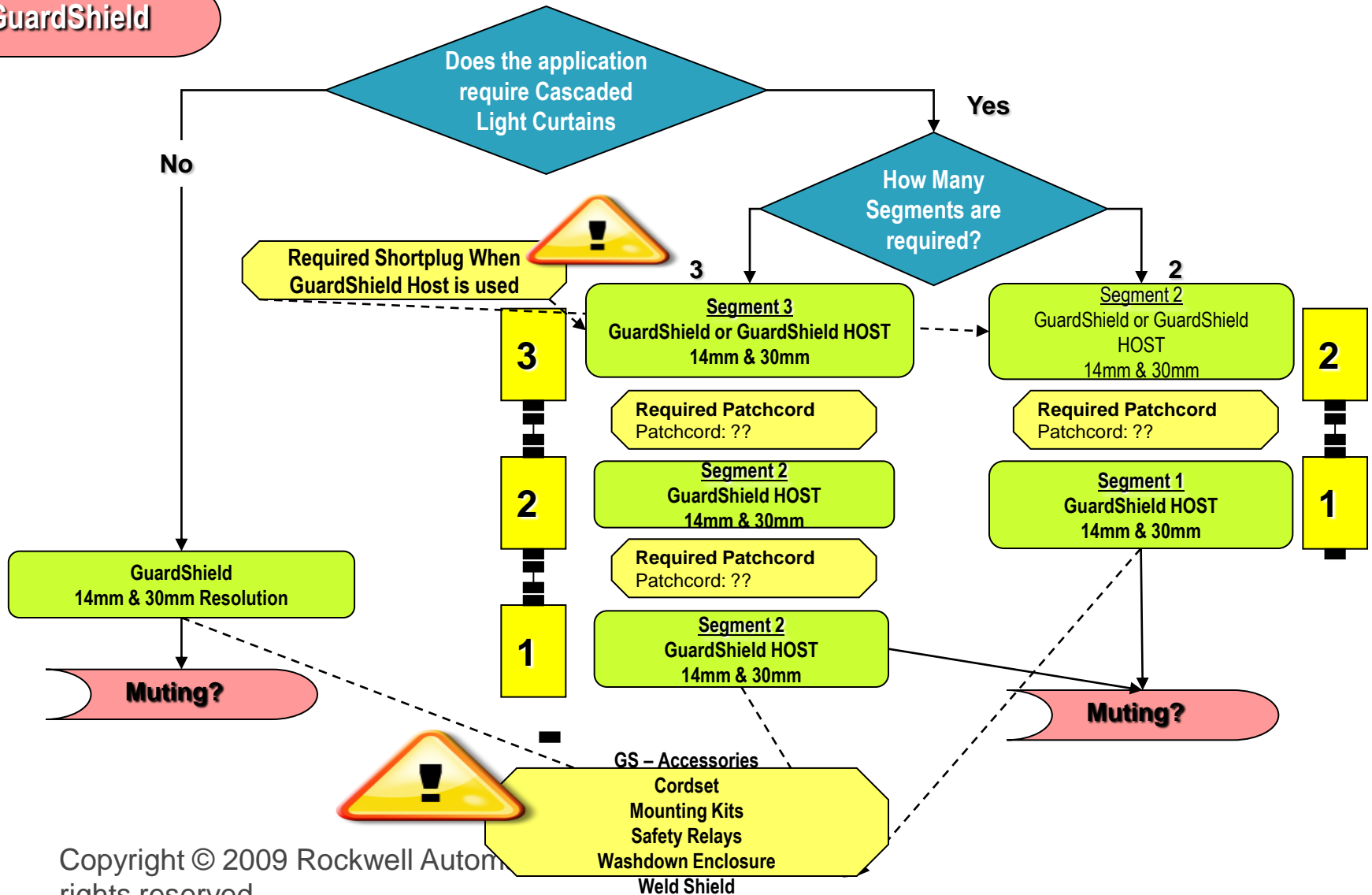

# PAC Selection Chart

## PAC

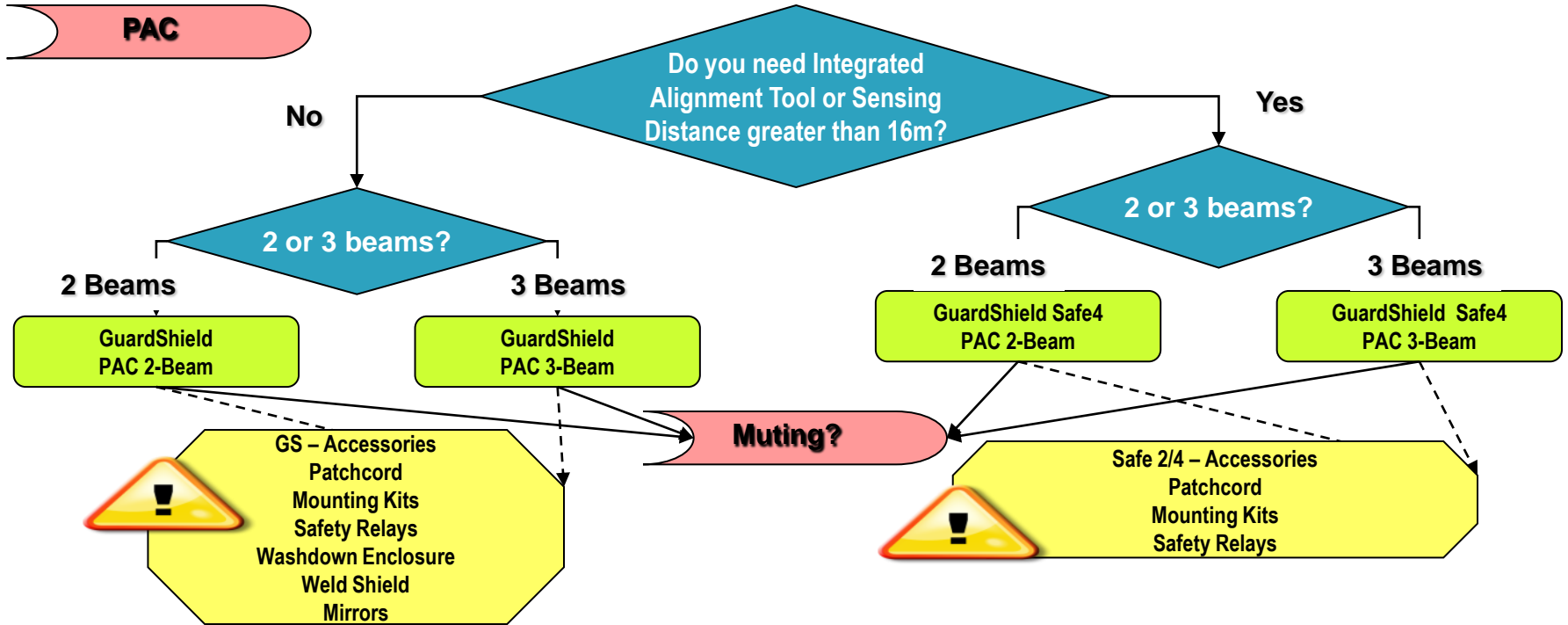

## Muting?

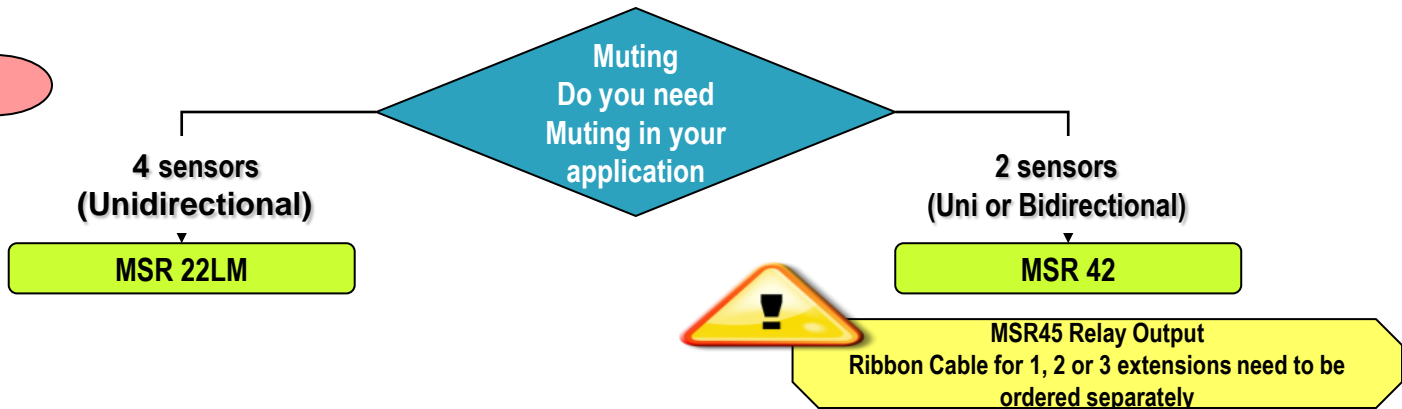

# GuardShield Family – POC Applications

(POC) Point of Operation – Type 4 , 14mm and 30mm resolution

- **GuardShield** – 16M range - Fully featured – Fixed / Floating Blanking, Muting, PSDI, EDM, Beam Coding, Aux output, Start / Restart interlock- **dipswitch selectable** modes
- **GuardShield Cascading** – 16M range - Interconnect two or three GuardShield Light Curtains with common pair of OSSDs
  - Same functionality as GuardShield
  - Used when safety distance allows a person to stand between vertical light curtain and hazard
- **GuardShield Remote Teach** – 16M range - Standard GuardShield with Y connector pigtail on receiver and remote Teach key switch
  - Designed for Remotely “Teaching” and re-teaching fixed blanking
  - Targeted to applications where fixed blanked area is repositioned one or more times during a work shift

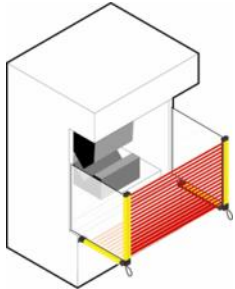

SAFEGUARDED

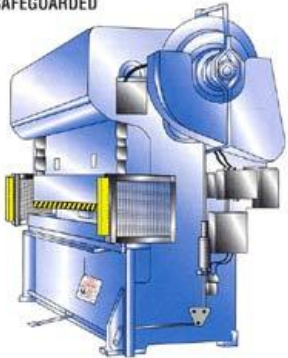

**GuardShield Safe 4** –9M (14mm) & 6M (30mm) range - On / OFF Functionality - Economical Integrated Laser Alignment system

**GuardShield Micro 400** – Requires Controller (MSR42) – 5M range – Two Configurable Aux outputs, two pair of configurable inputs – additional safety devices can be added, two or four sensor muting, configurable OFF delay outputs, EDM, manual Start / restart.

- No Dead Space – The Micro 400 transmitter and receiver have less than an inch of dead



# PAC Options

## GuardShield 2 and 3 beam PAC

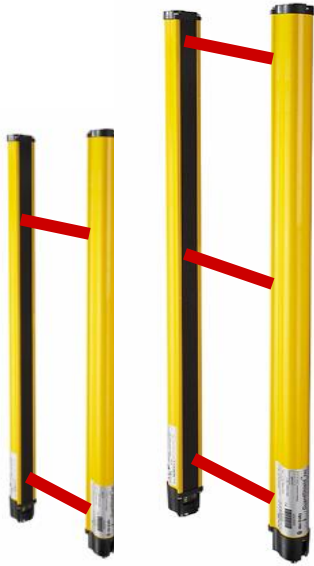

- 16 meter operating range
- Beam Coding
- EDM
- Start / Restart Interlock
- Aux output (500ma)
- 2 beam @ 500mm in 640mm housing
- 3 beam @ 400mm in 960mm housing

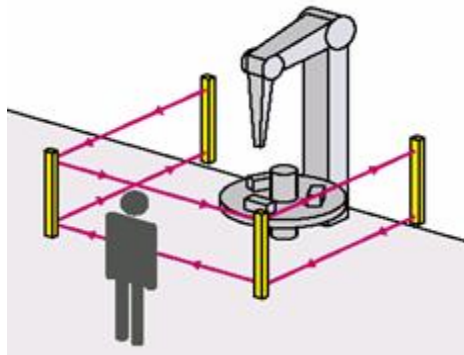
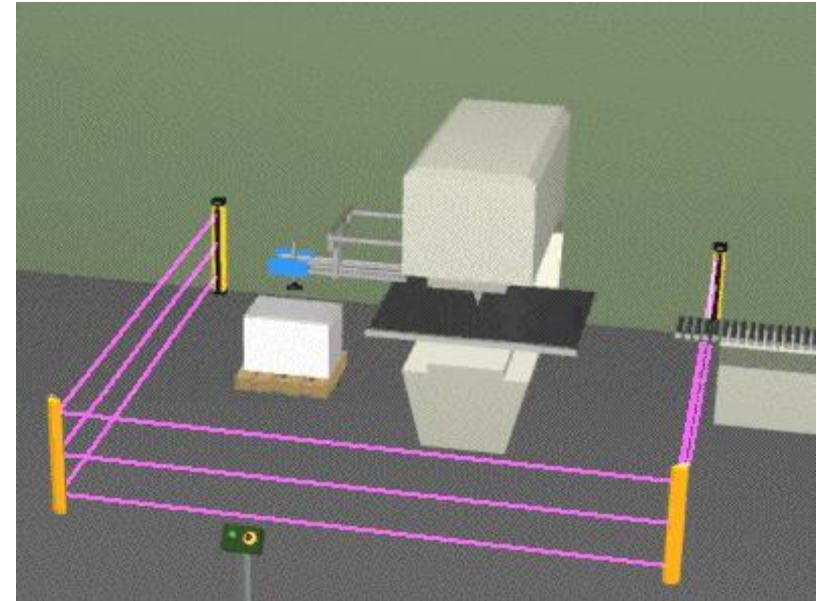

## GuardShield Safe 4 PAC 2 and 3 beam

- 30 meter operating range
- 120mm active segments
- ON / OFF Functionality
- 300ma OSSDs
- Economical solution



# How To Inhibit Machine Access

---

**MUTING**

**FIXED BLANKING**

**FLOATING BLANKING**

**CASCADING**

**LASER**

# MUTING

Muting is a way to allow objects or material to pass through the Light Curtain's sensing field without stopping the machine process

## 4 SENSOR MUTING

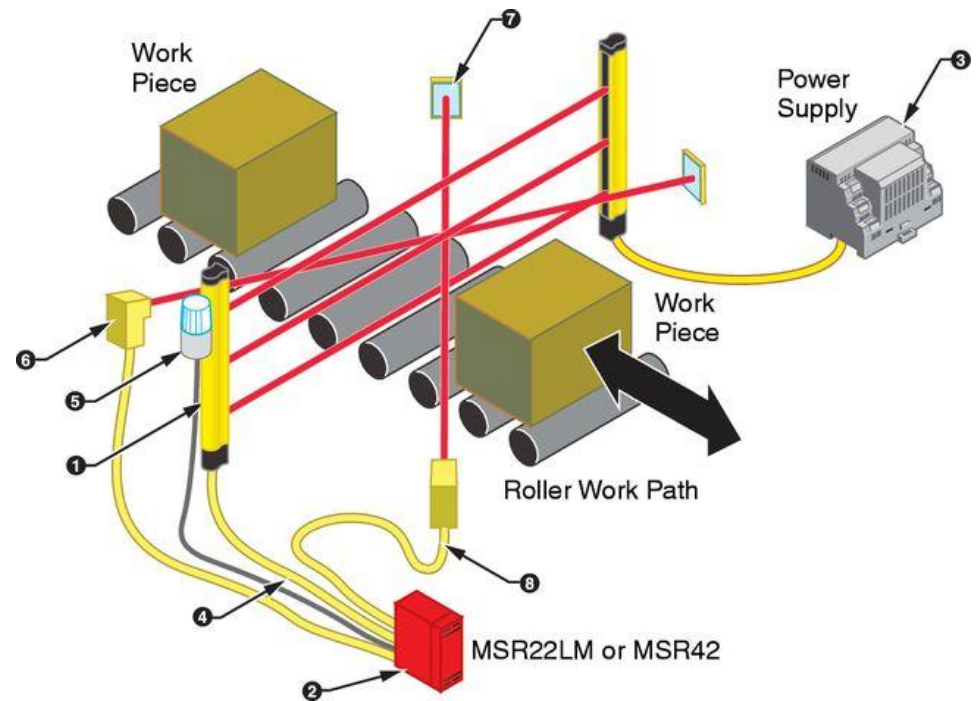
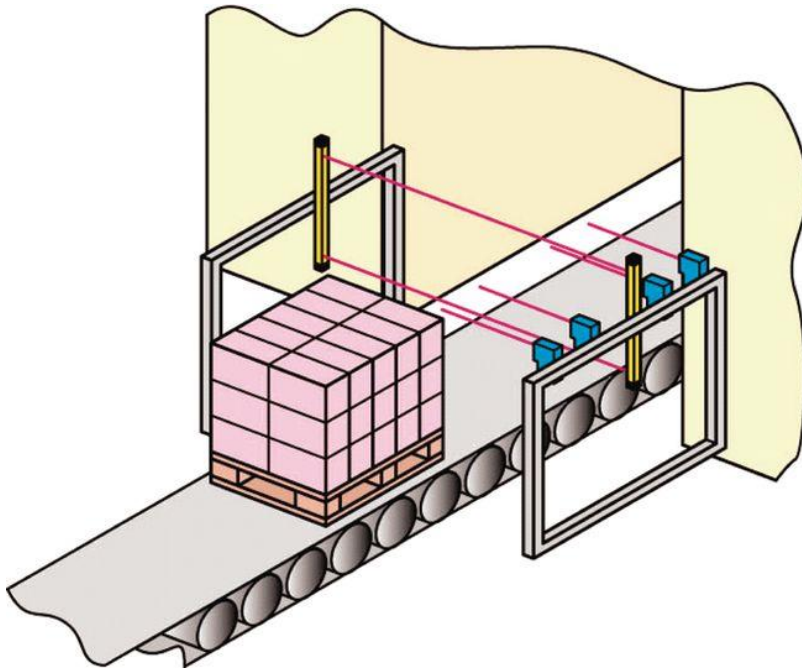

## 2 SENSOR X-PATTERN

# 4-Sensor / Light Curtain Sequence

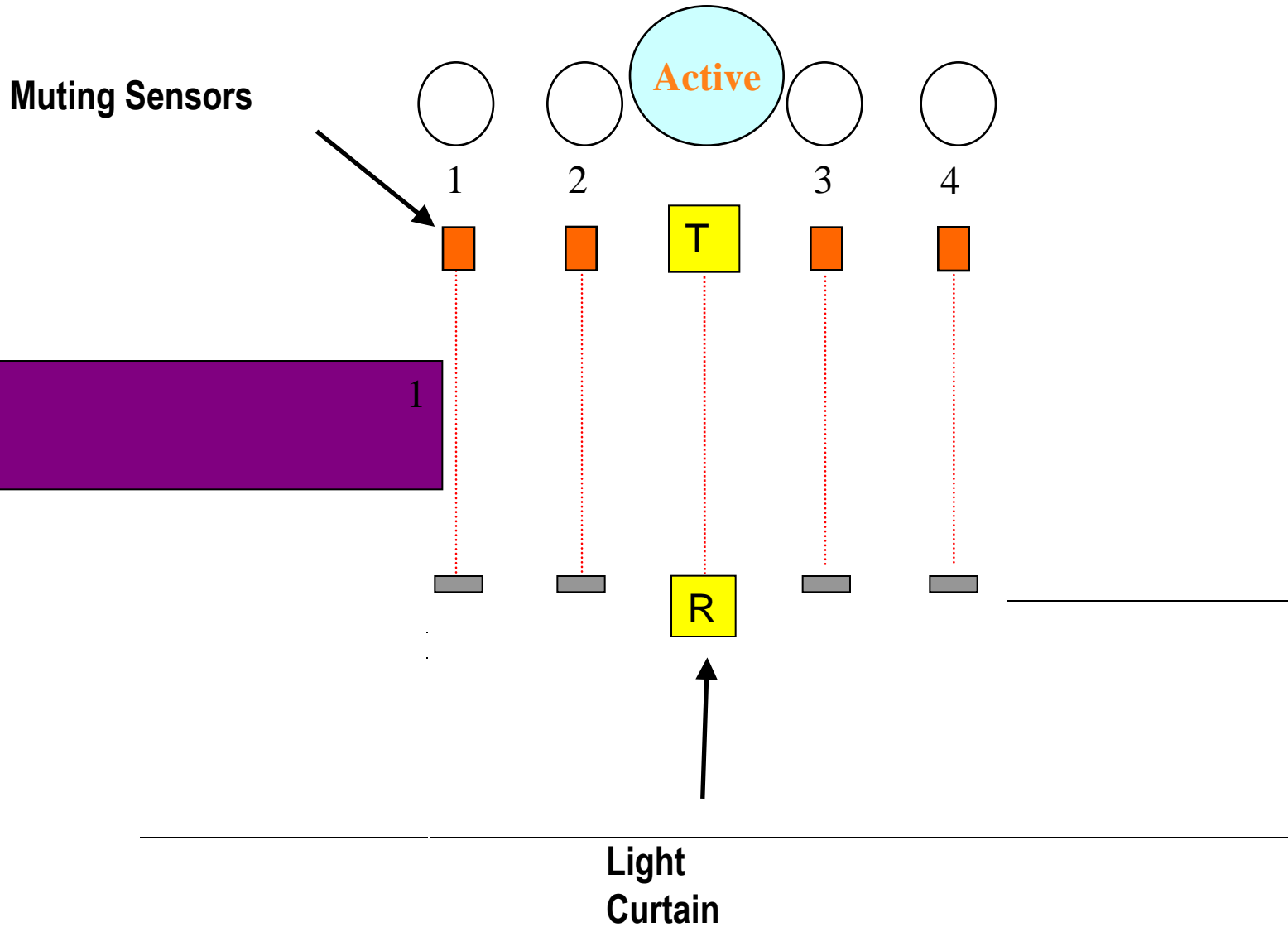

# 4-Sensor / Light Curtain Sequence

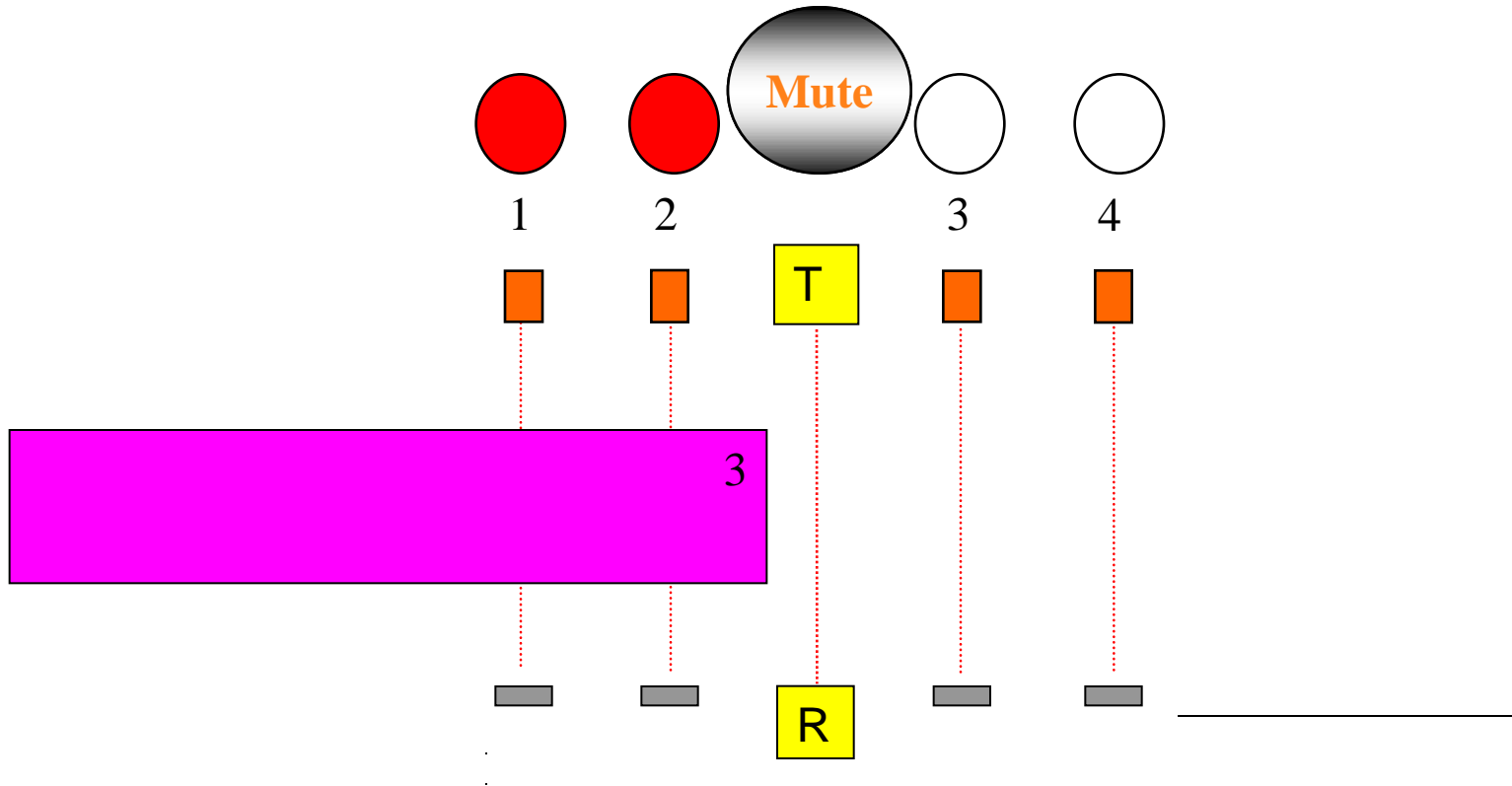

Muting is activated when the material interrupts Sensor 2

# 4-Sensor / Light Curtain Sequence

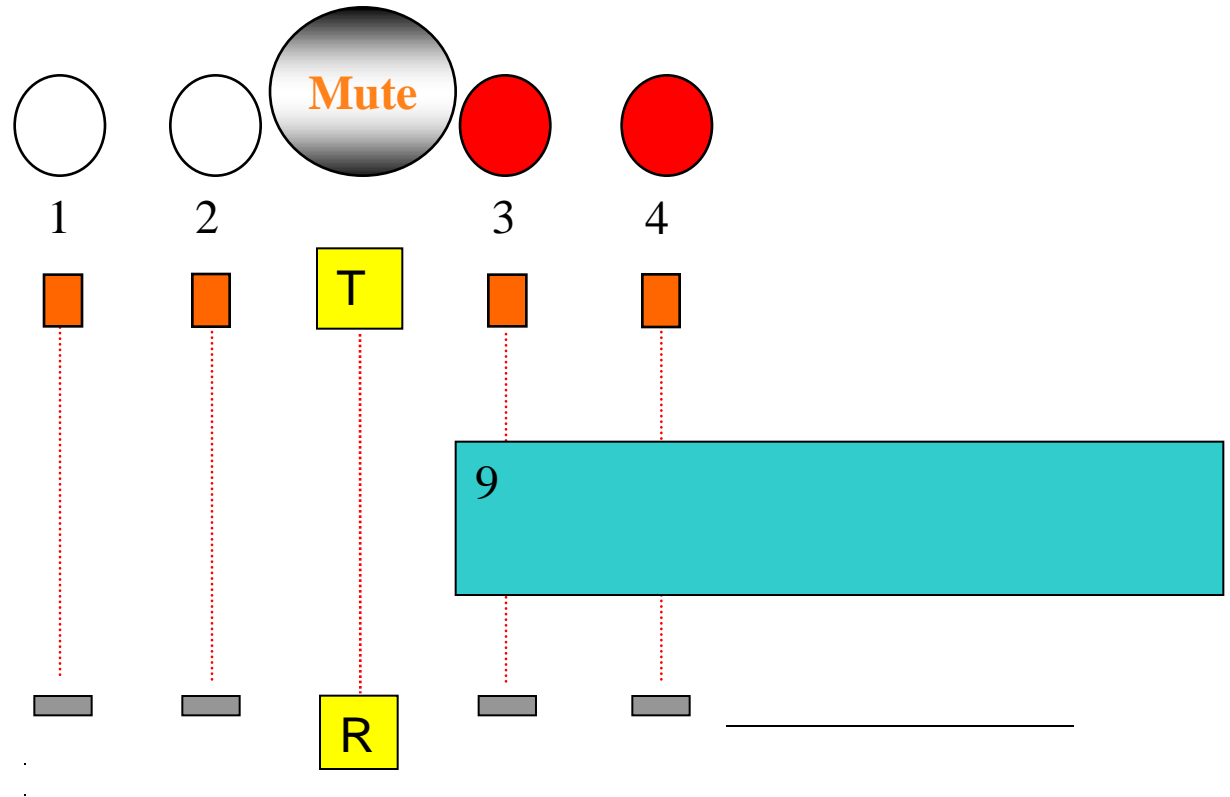

Muting is active until the material clears Sensor 3

# 4-Sensor / Light Curtain Sequence

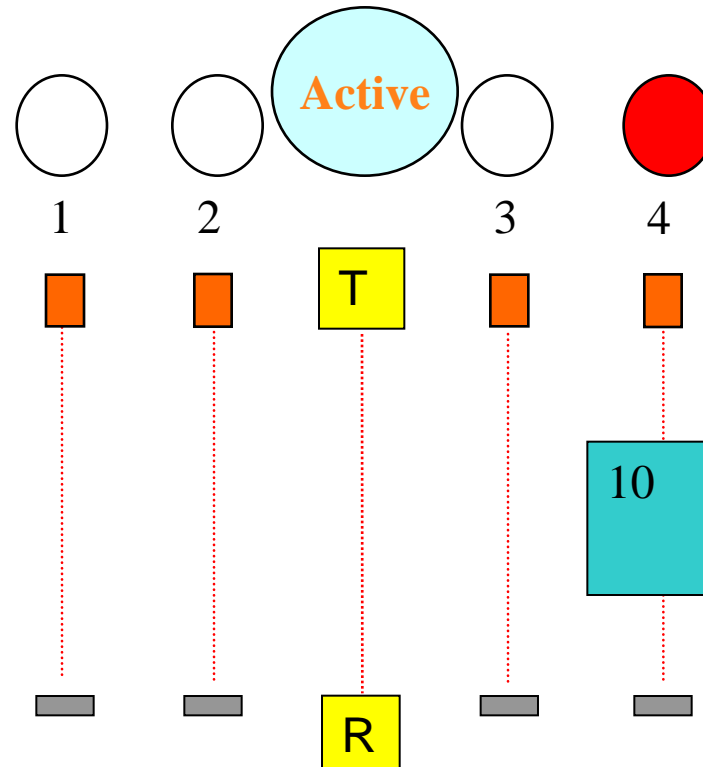

**Muting is now deactivated, however the material must clear Sensor 4 before Sensor 1 is interrupted for the next muting cycle or a Lock out will occur.**

# GuardShield PAC with Muting - Operator Detected

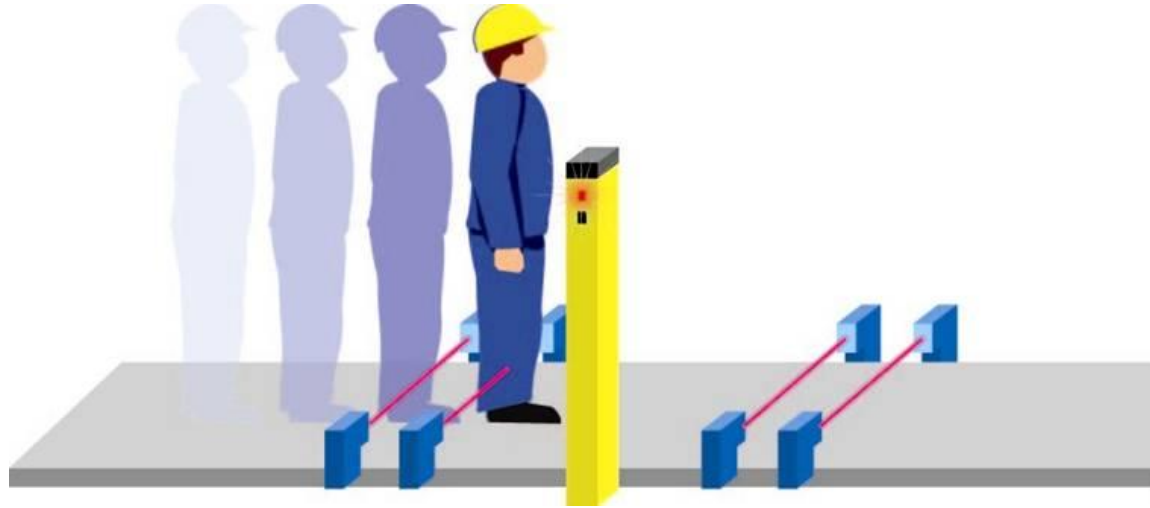

- Operator is detected due to muting conditions not being met and Machine is stopped
- The Safety Relay must see a consistent sequence of events and is best suited for conveyORIZED muting applications
- The sensors must be blocked within predetermined timing sequence or muting will not be activated

# MSR42 – Multi-function Safety Relay

Components that can be connected to the MSR42

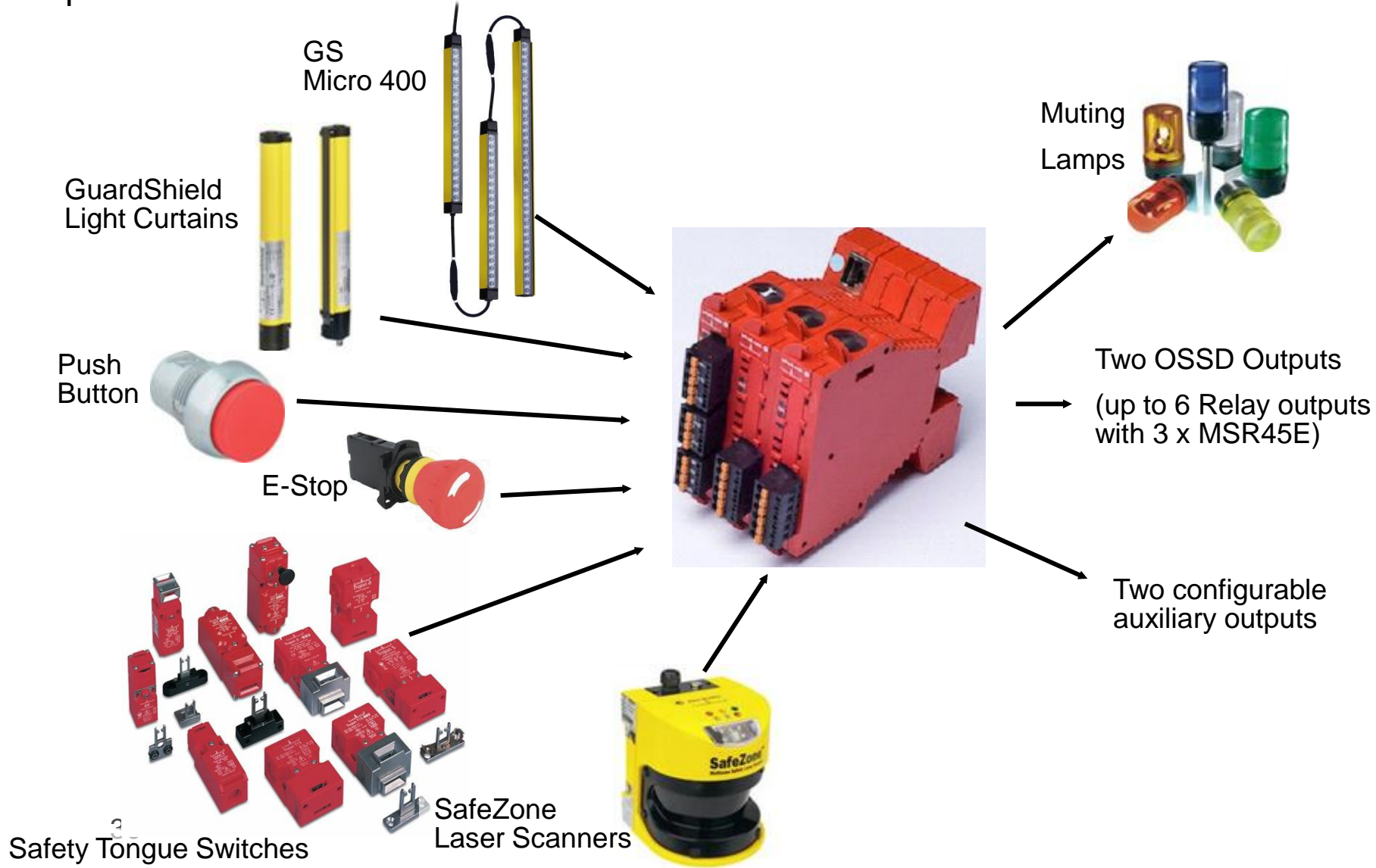

# MSR42 – Muting Functions

- Different types of muting can be configured (2 and 4 sensors)

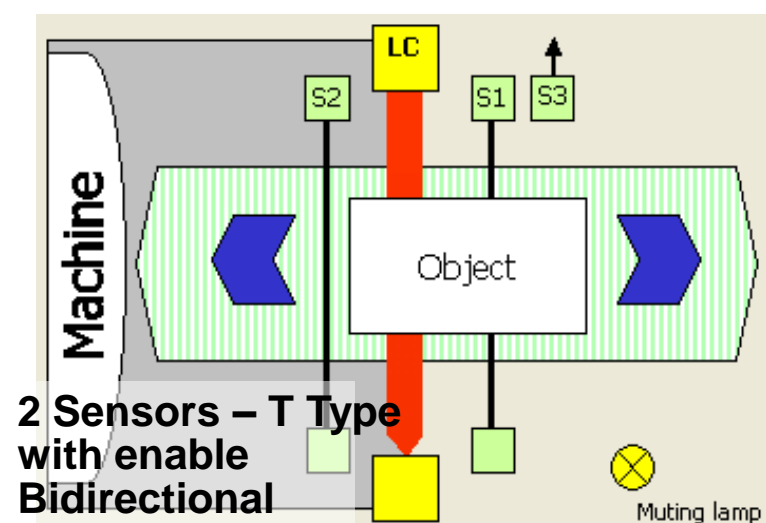
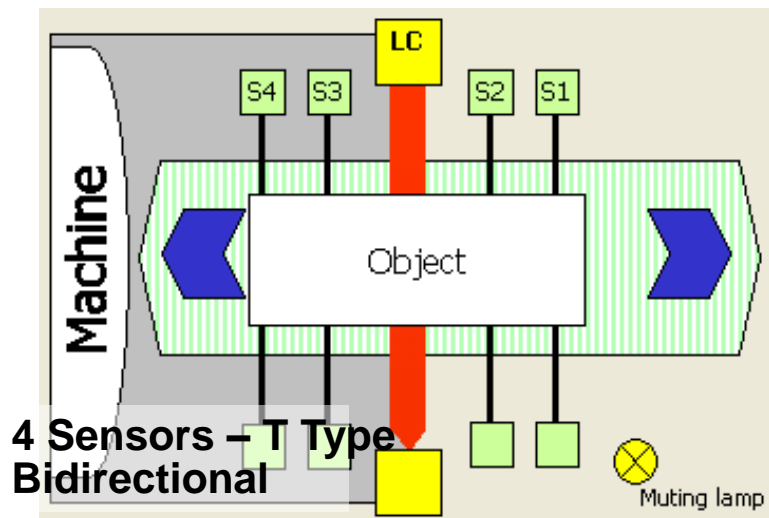
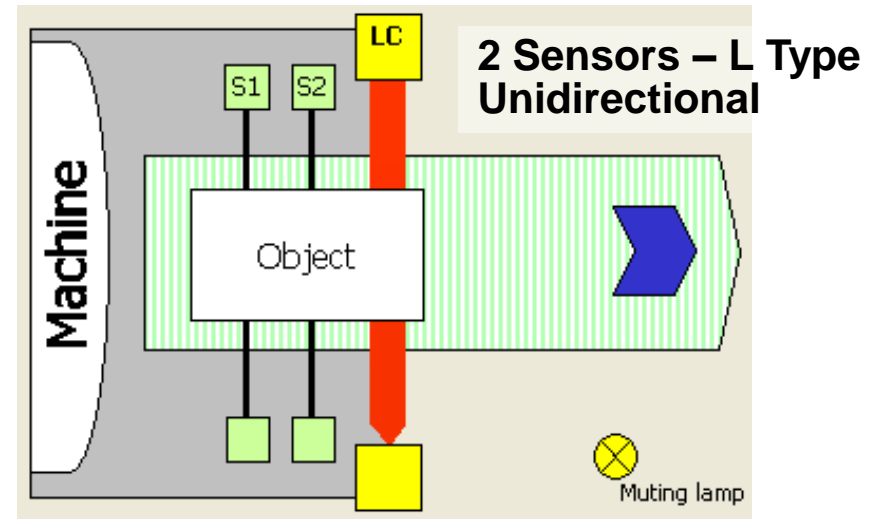
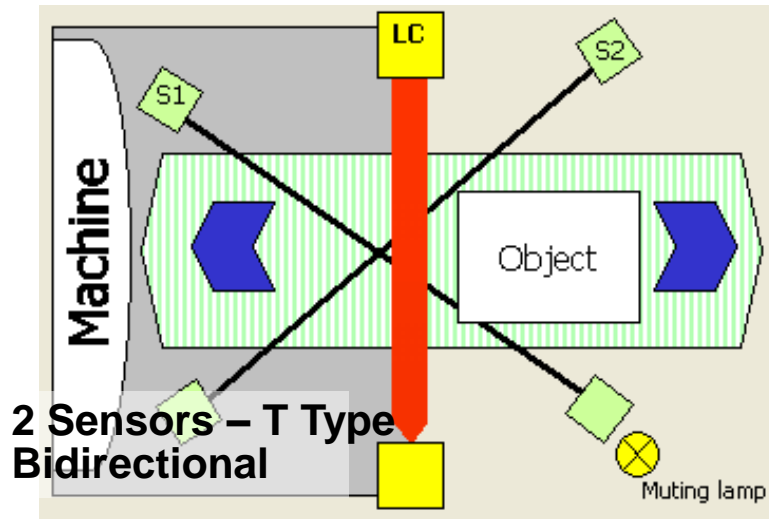

# FIXED BLANKING

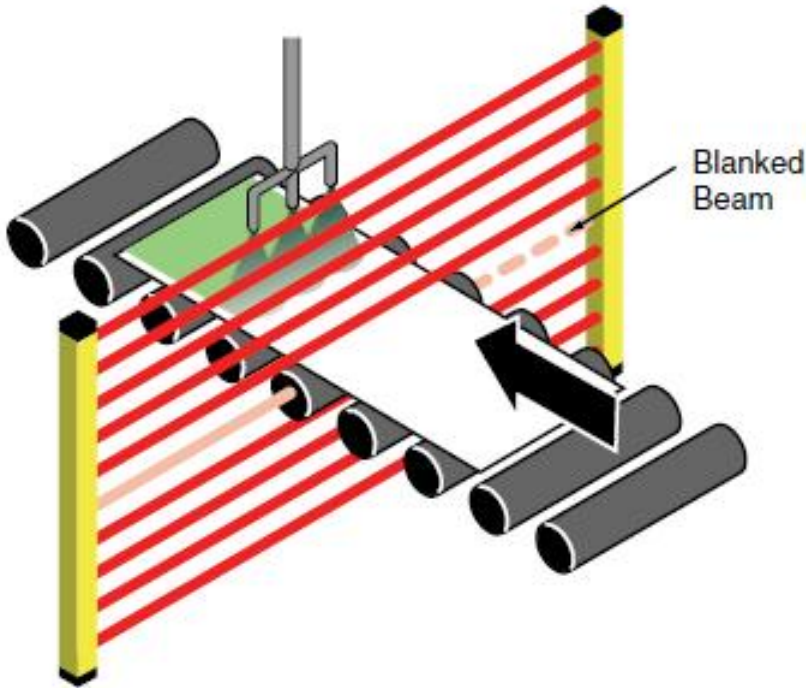

Workpiece holder

## Typical Applications – Conveyor or Work piece Holder is fixed in Light Curtain

- The light curtain must be taught the location of the obstruction.
- This means that the object must always reside in the light curtain, and always at the same location. If the object is moved or removed, the light curtain deems this action as a fault and goes into a lockout state.

# Floating Blanking

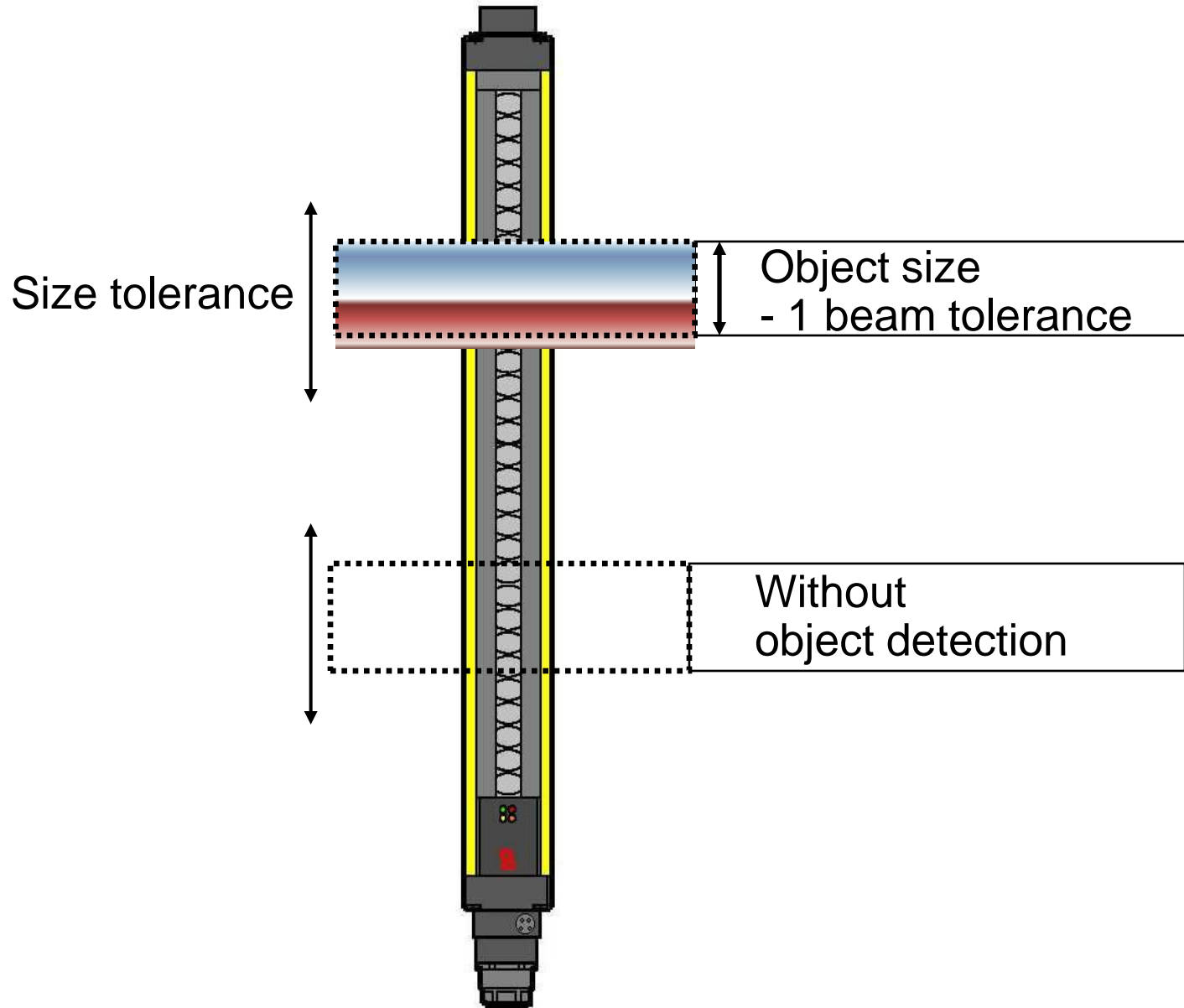

# Cascading Curtains

---

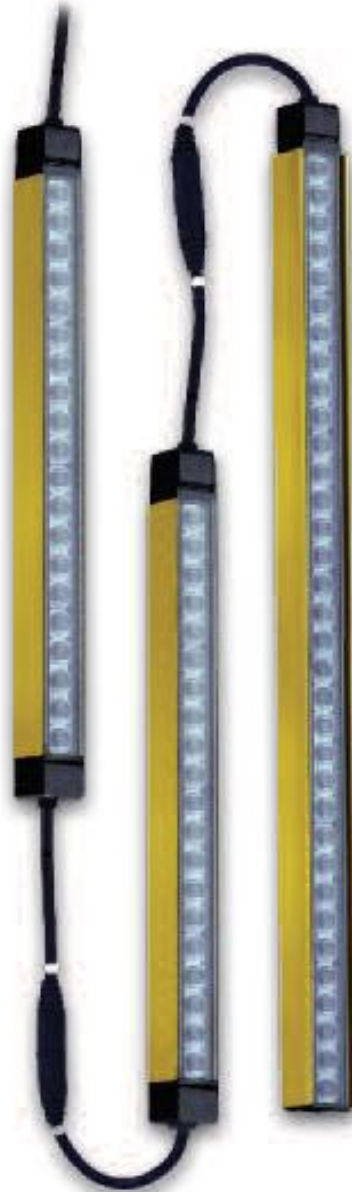

# What Is Cascading?

- Cascading is a term that refers to the ability of safety light curtain segments to be inter-connected resulting in a single pair of OSSD's.
- Cascaded light curtains are usually comprised of a single pair of light curtains mounted vertically at the required safety distance and a Horizontal segment pair located between the Vertical light curtain and the hazard..
- Cascaded segments can be of mixed resolutions and protective heights



**Reach over protection**

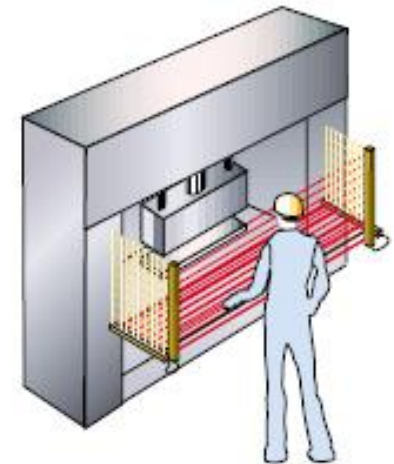

**Horizontal LC  
provides pass  
through detection**

# SafeZone Singlezone and Multizone

## Multizone



## Singlezone



- Four configurable, switchable field sets
  - Field set is one Safety and one Warning field
- 5 meter safety field operating range
- Single configurable field set
  - Field set is one Safety and one Warning field
- 4 meter safety field operating range

All other functionality in both scanners is the exactly same

# Laser Scanner -

## Stationary Vertical Applications

---

- Stationary – Vertical (Approximately 5% of Applications)
  - Configurable resolutions for hand, arm (POC) and whole body (PAC) detection.
  - Required to have functionality to program in a fixed point in the safety field which prevents manipulation of the device
  - Used similar to a safety light curtain, however response time is 60ms and longer

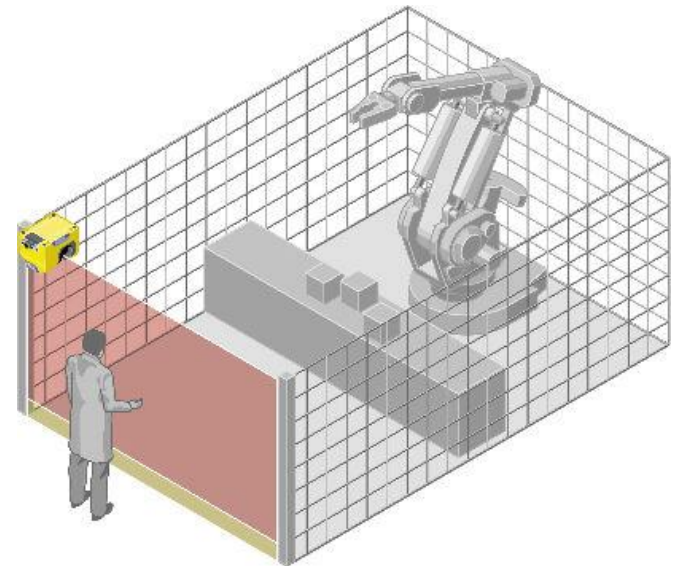
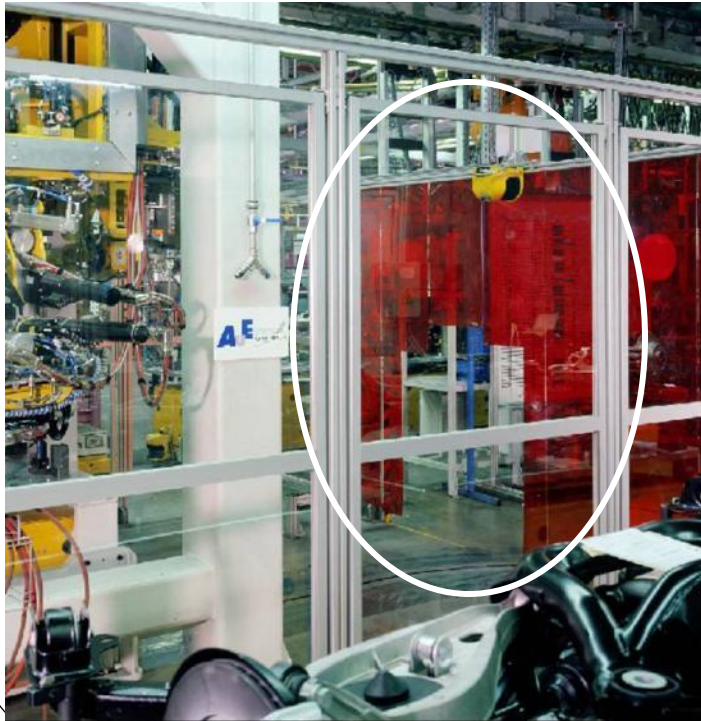

# Laser Scanner –

## Horizontal Stationary Applications

- Stationary – Horizontal (Approximately 65% of Applications)
  - Represents the majority of applications, 70mm resolution required for leg detection, 190° scan angle
    - Single field set ( Warning and Safety)
    - Two switchable field sets – Material handling apps
    - Typically 4M safety field is required although some apps require longer safety field ranges.

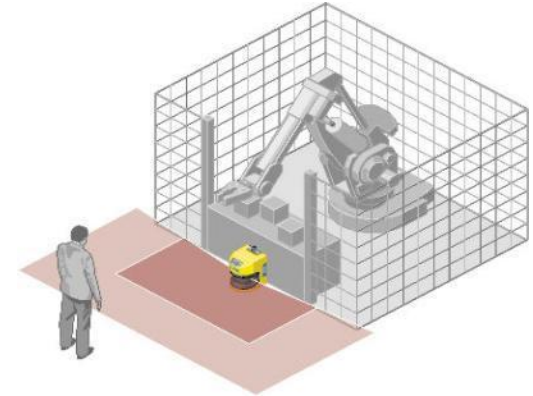

**Single Field set**

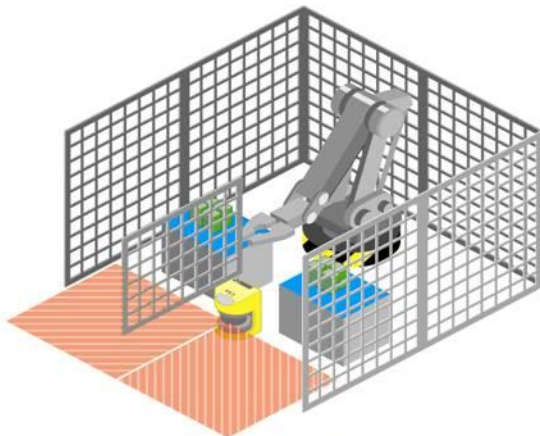

**Two Switchable Field sets**



**Pipe bending machine**

# SafeZone Mounting Orientation

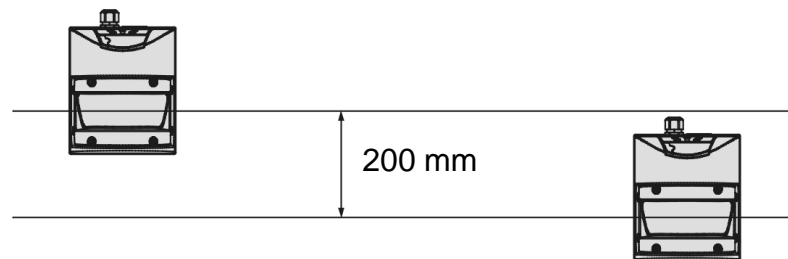
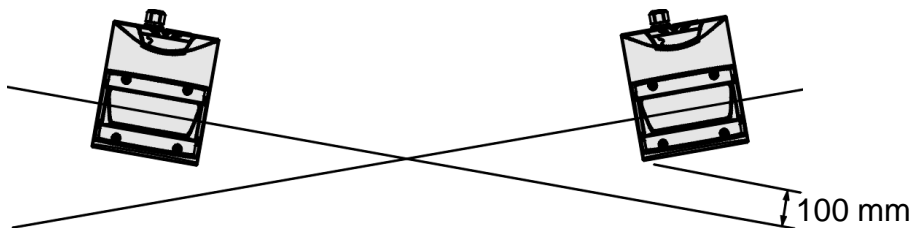
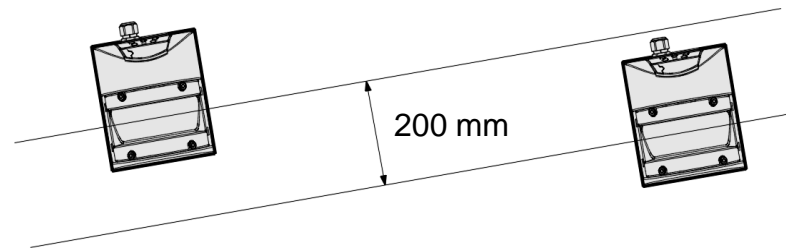
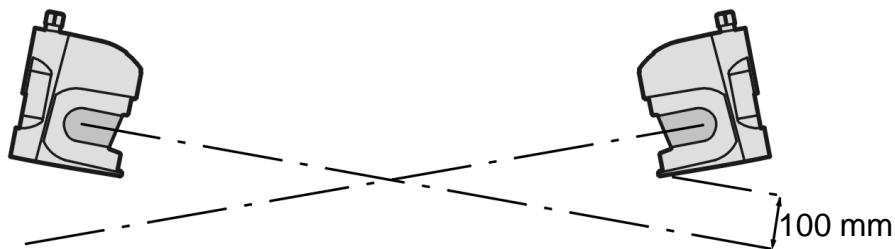

If more than one SafeZone is used in general proximity to another, it is necessary to mount each in such a manner to prevent optical interference

# Horizontal Stationary Mounting Considerations

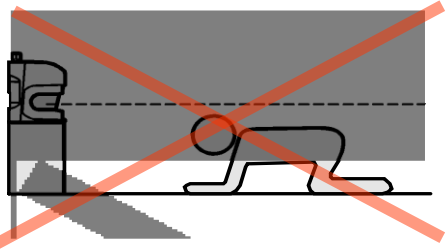
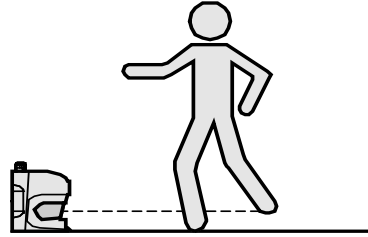

Prevent crawling underneath  
(Scan height max. 300 mm)



Prevent standing behind!

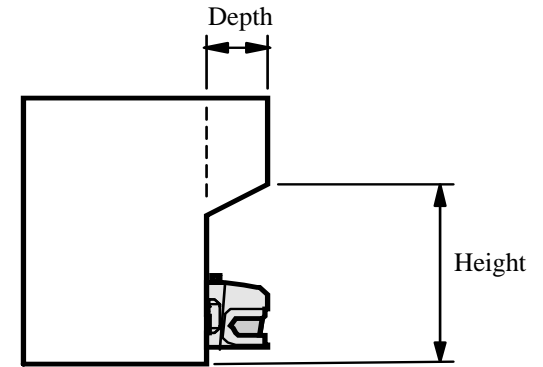

Mounting in a recess

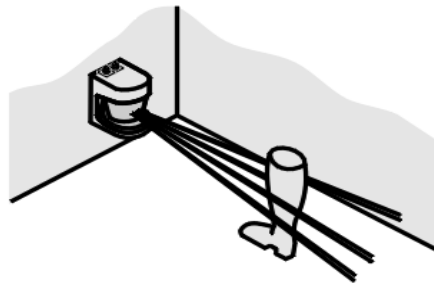
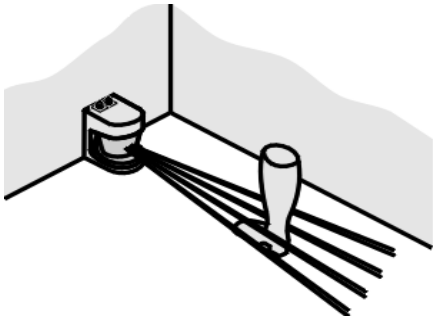

Consider resolution for leg detection!  
(at ankle height, 70 mm are be not enough!)

# SafeZone Mounting Requirements

Reaching/Climbing behind safety fields  
stationary applications

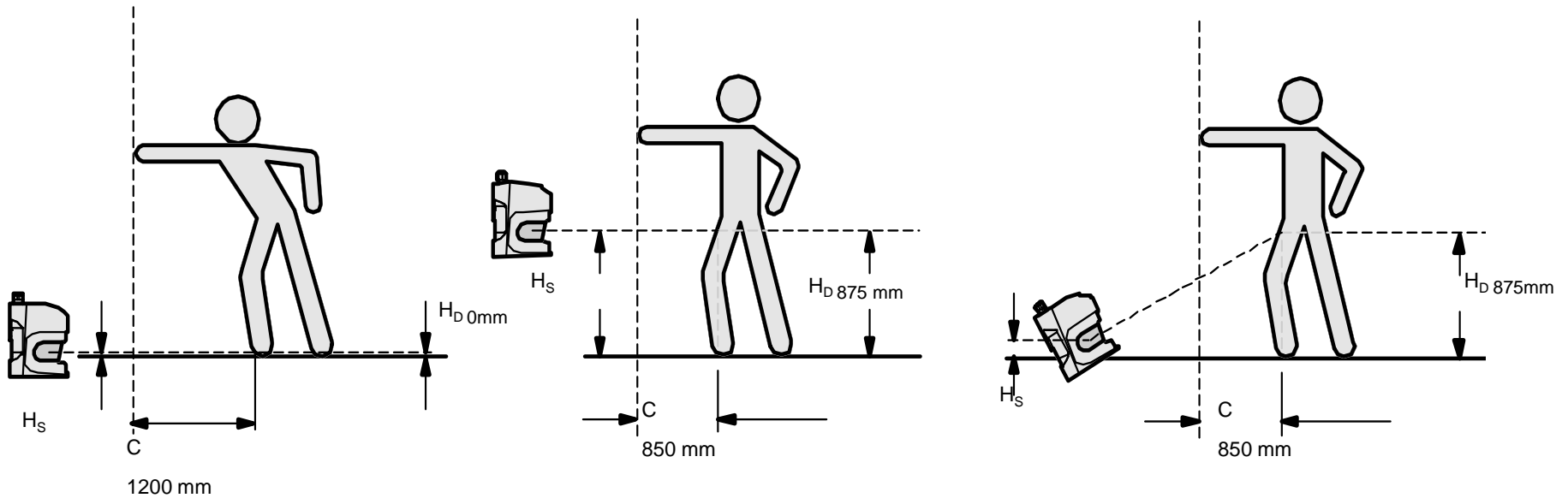

Calculation of min. distance C:  
 $C = 1200 \text{ mm} - (0,4 \times H_D)$

# PAC Light Curtain Application

Possible to use;

- GuardShield Safe 4 PAC
- GuardShield PAC
- GuardShield POC
- GuardShield Safe 4 POC

With the following muting modules;

- MSR 42
- MSR 22LM
- MSR 300

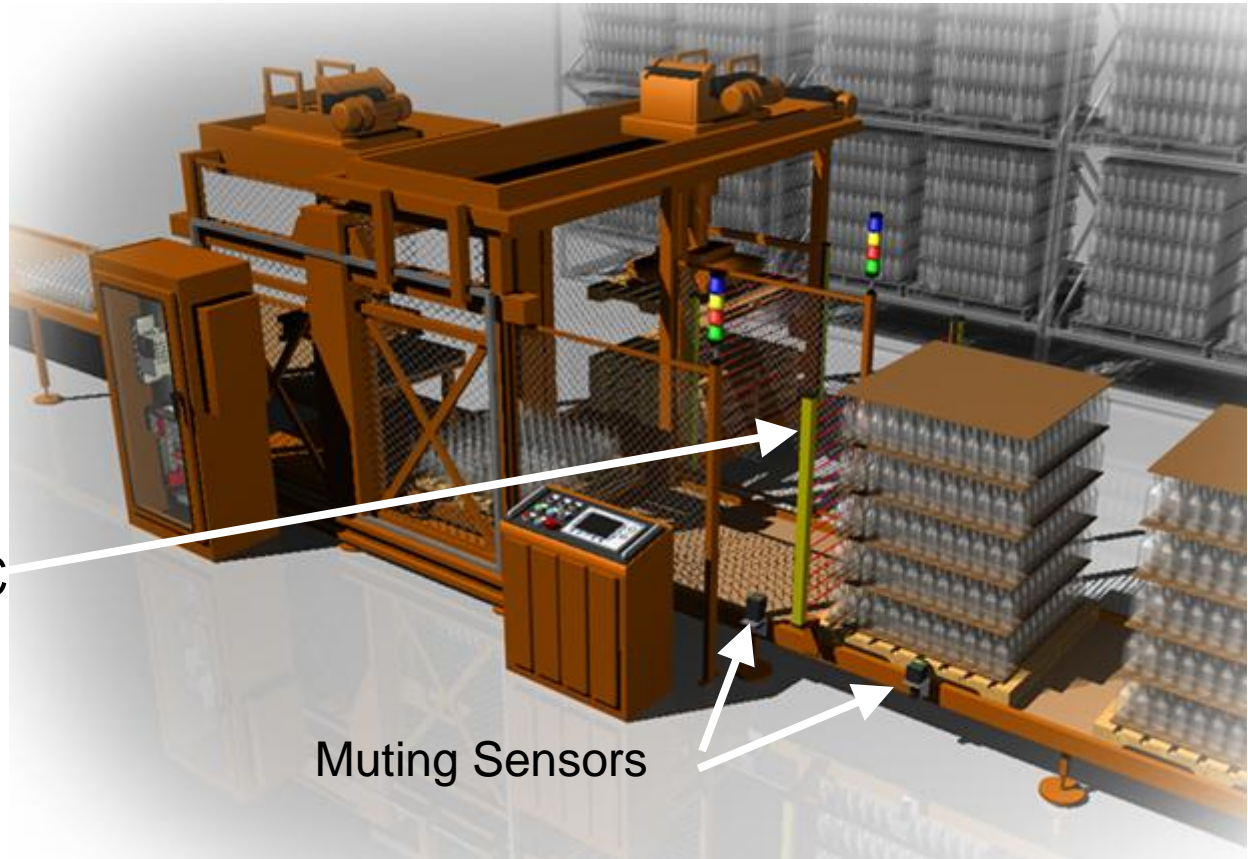

# Robot Cell Application

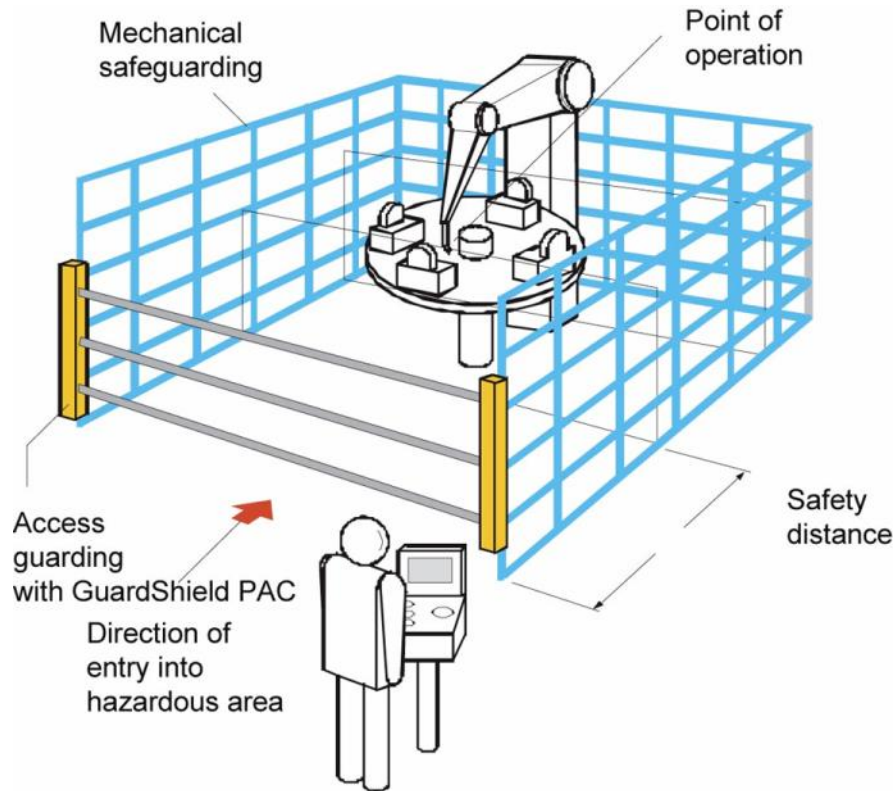

## Application Possibilities;

- **GuardShield PAC**
  - EDM eliminates need for MSR 127 safety relay
- GuardShield Safe 4 PAC
  - Requires a safety relay
- GuardShield POC, 30mm if access opening within range of device
- GuardShield Safe 4 POC 30mm
- AAC
- SafeZone

# PAC Application – Exit End Muting

---

- 3 beam PAC with 2 sensor exit muting

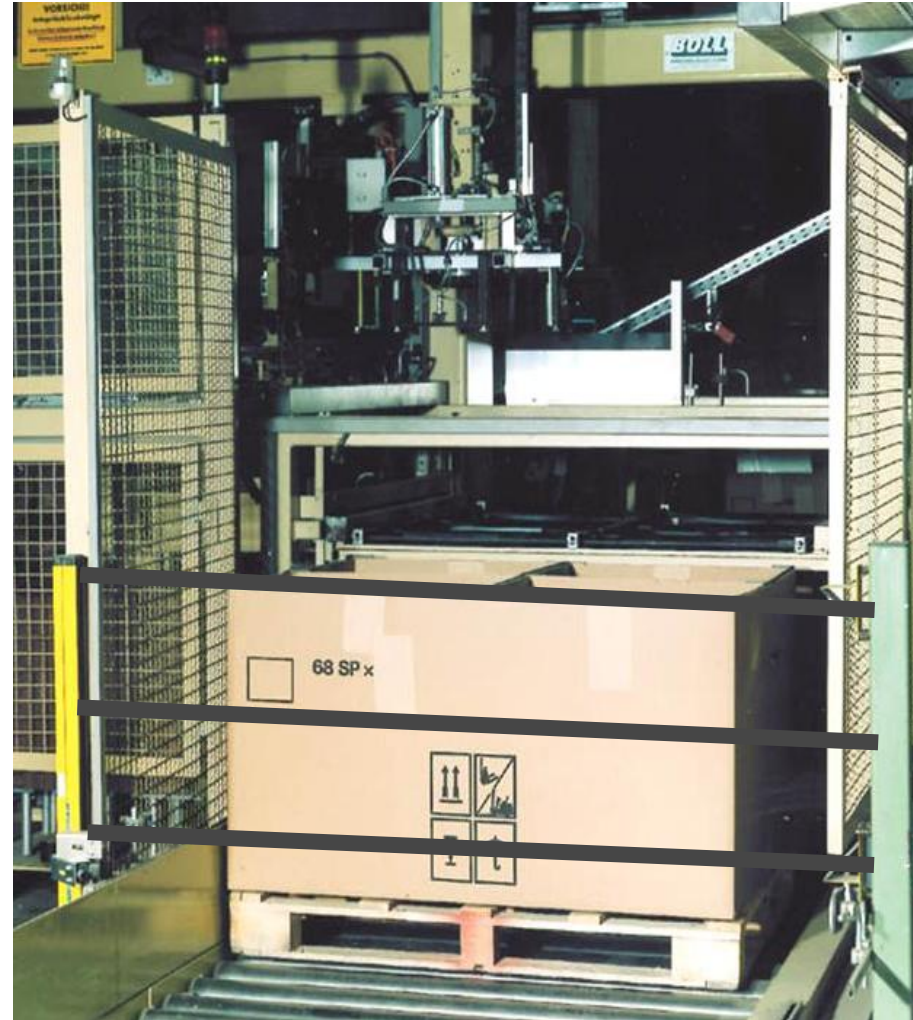

# Tube Bending Machine

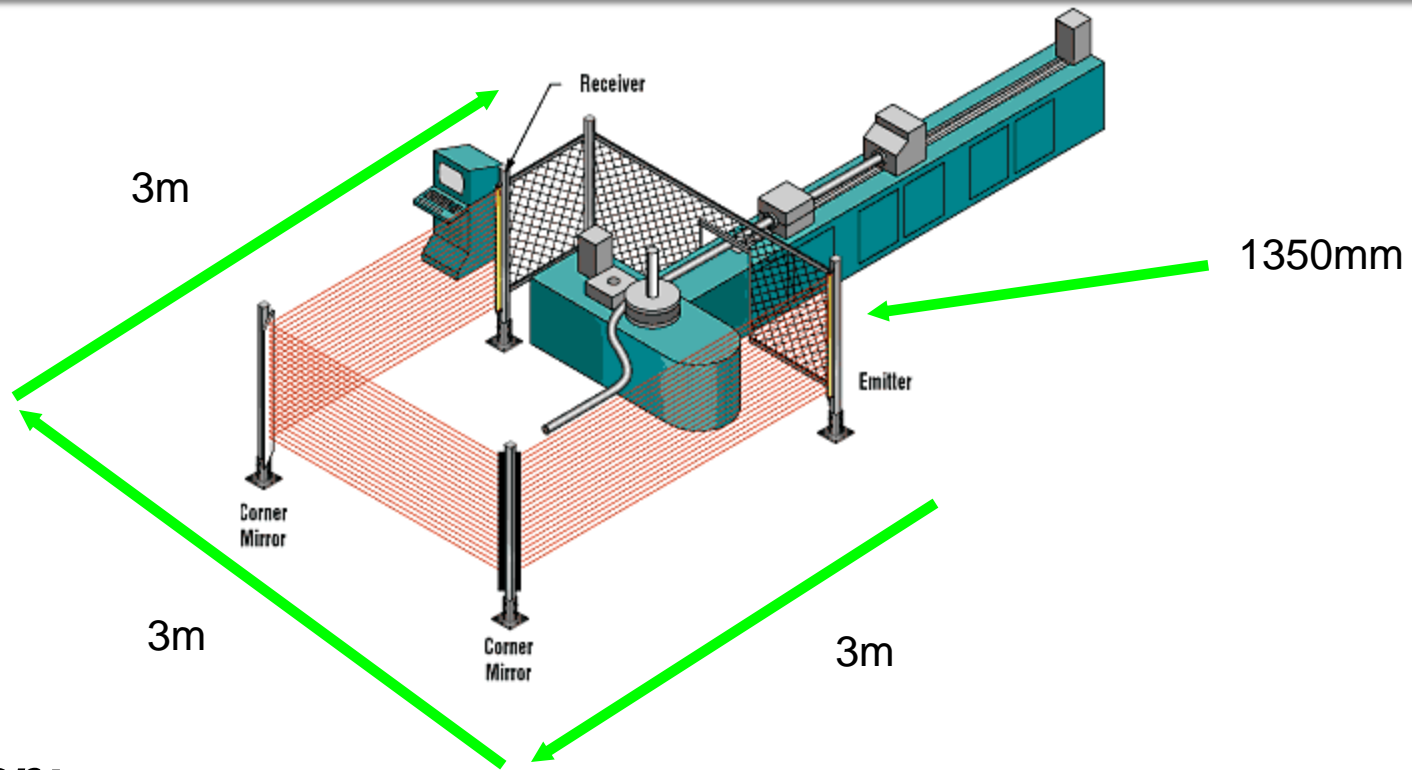

## ***Application:***

Perimeter guarding of a tube bending machine.

## ***Guarding:***

Three sides are guarded with a light screen and one side is guarded with hard guarding.

# Multiple Guarding Devices

---

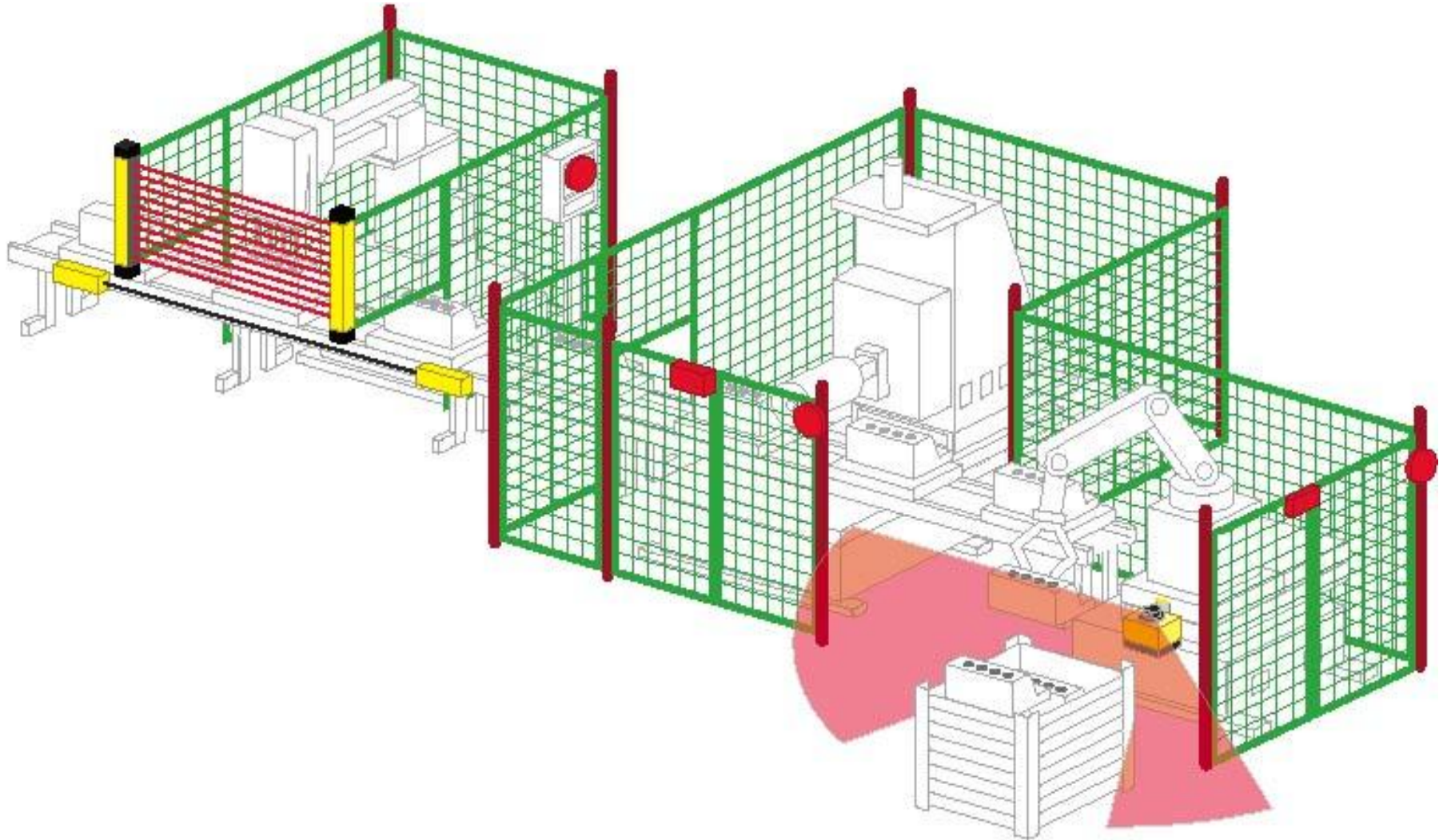



# In Summary

---

- There are many devices which can be used to protect personnel from equipment or machinery hazards
- Perform a risk assessment to identify all of the hazards on the machine before selecting the device.
- Determine type of application, POC, PAC, AAC
- POC application- Before selecting protective height and resolution determine the required safety distance
- Select the proper protected height to prevent reaching over or under the safety device to access a hazard
- POC products can be used in POC, PAC and AAC applications, however PAC and AAC devices should not be used in POC applications.
- Always “commission” the installation of safety devices to assure that they perform as intended and expected.

The End!