

LISTEN.
THINK.
SOLVE.SM

LEADING EDGE SOLUTIONS FOR MACHINE SAFETY APPLICATIONS



Schaedler
yesco



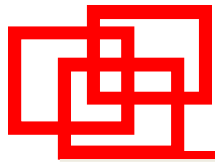

SENSAGUARD

NON-CONTACT SAFETY SWITCHES



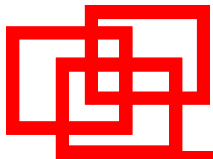

SENSAGUARD – RECTANGULAR FLAT PACK

Status/Diagnostic LED

- **Red illumination:**
 - Guard Door Open (Output off)
- **Green illumination:**
 - Guard Door Closed (Output on)
- **Amber illumination Flashing:**
 - Guard Door Closed (Output on), unit is reaching maximum sensing distance.

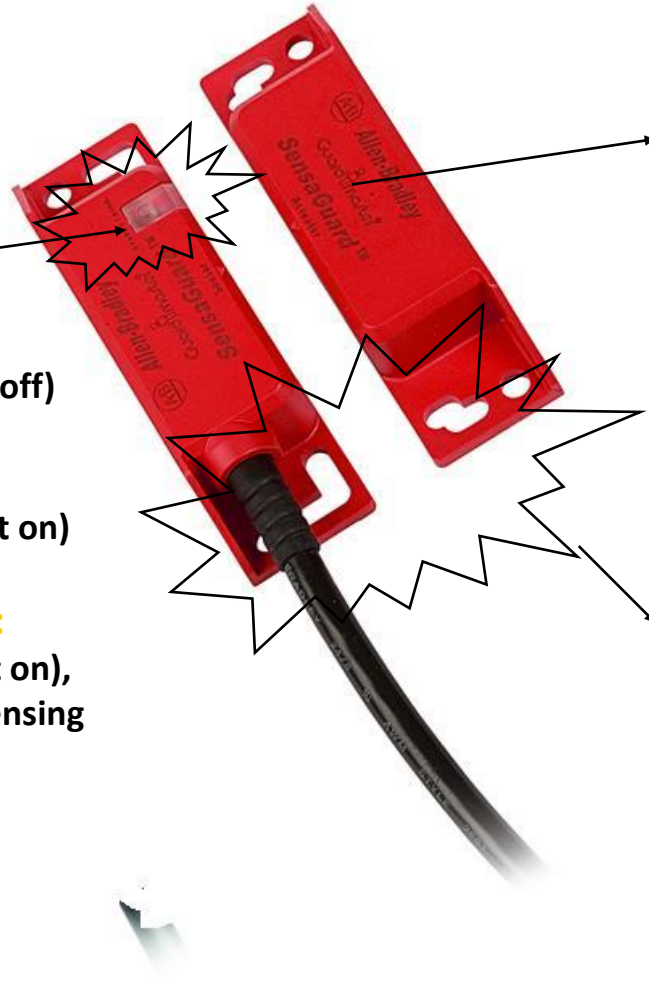

Laser etched:
The product information is laser etched on to the product for traceability.

Universal mount Mounting:
Same bolt hole pattern for mounting our existing Ferrogard and Sipha product as well as our competitors.

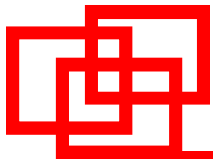

SENSAGUARD – RFP – MARGIN INDICATION FEATURE

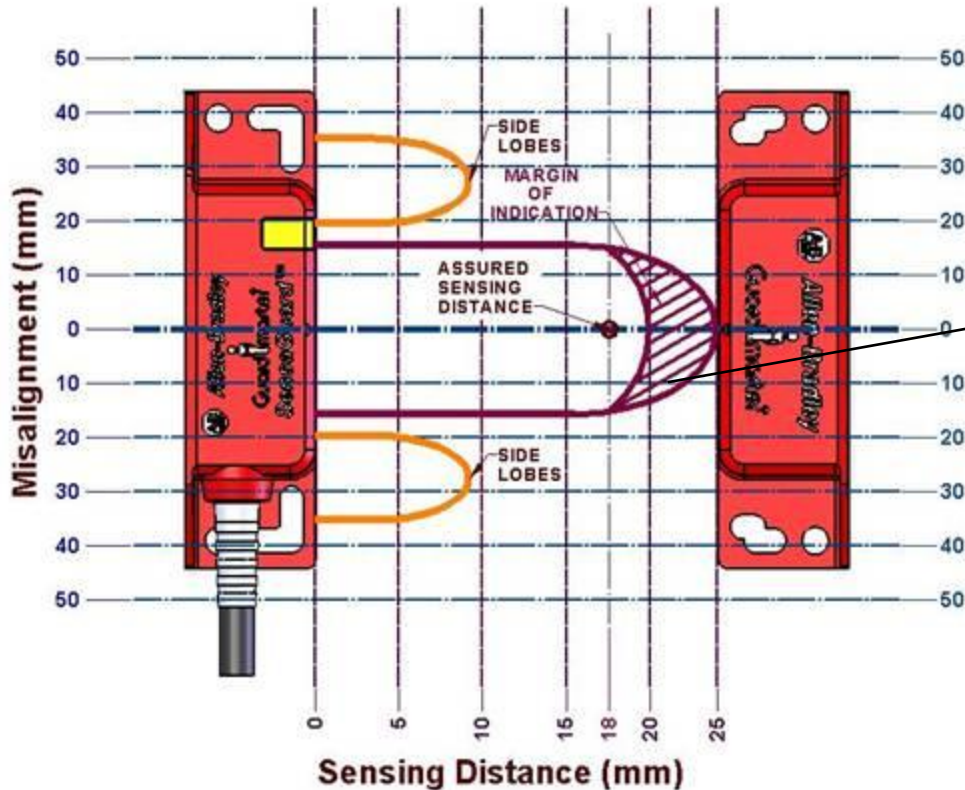

Margin Indication Feature:

When the unit is reaching maximum sensing distance the Status/Diag LED will light **Amber** warning the customer that the sensor and actuator should be re-aligned. The output circuit will work normal as if the unit was in range and the Status/Diag LED was **Green**.

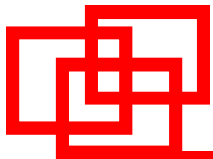

GUARDSHIELD MICRO 400

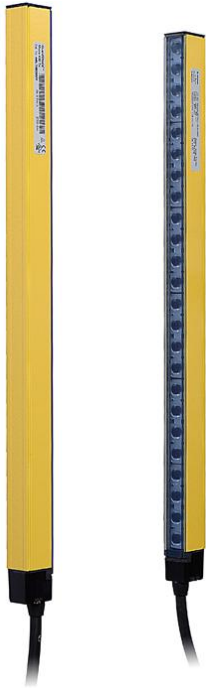

- ON / OFF functionality with MSR42 Controller “Out of Box” configuration
- Micro 400 Outputs are data only, functionality is through controller
- Micro 400 Environmental Rating: IP 54
- GuardShield Micro 400 System; GuardShield Micro 400 pair and MSR42 Controller is rated SIL3_{CL} per IEC 61508, cULus listed and CE marked.
- Operating Temperature 0 to 55°C
- 940nm wave length
- Very small profile (15mm X 20mm) with integrated 20 inch pigtail cable and 8 pin M12 connectors
- A pair of dedicated patch cords are required to connect the integrated pigtail cable M12 connectors to the RJ45 connections of the MSR42
 - Offered in 3M, 5M & 8M lengths
 - Same part number for transmitter and receiver patch cords

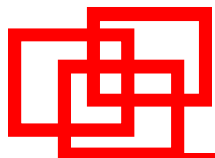

GUARDSHIELD MICRO 400

- Economical Three box (Transmitter, Receiver and Controller), Type 4 safety light curtain per IEC 61496
- Functionality is through MSR42 control module – can add on up to 3 MSR45E safety relay expansion modules to the MSR 42 Micro 400 controller
- 24 Vdc +/- 15%
- 14mm – Finger detection
- 30mm resolution – Hand detection
- 5 Meter operating range
- 150mm up to 1200mm protective heights in 150mm increments
- Response times vary by protective heights and Controller configuration

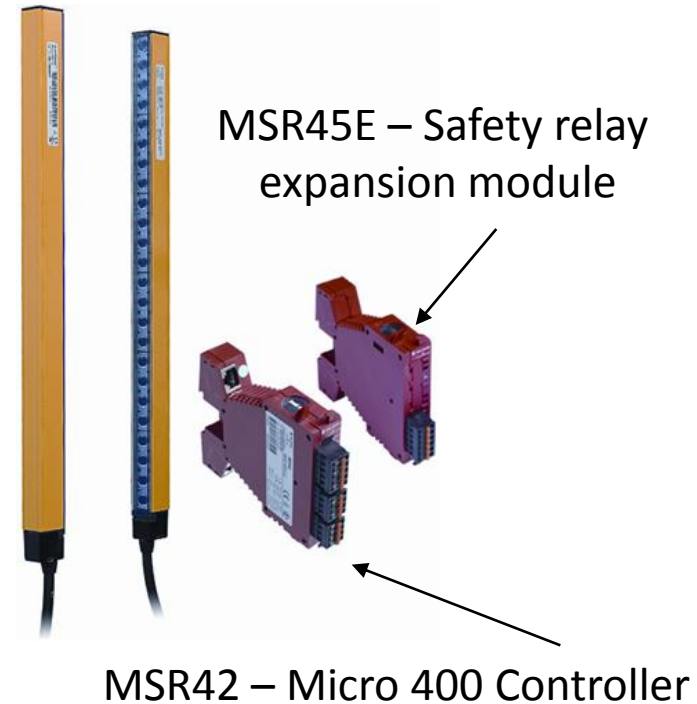

Competitively priced, 3 box system (Transmitter, Receiver, Controller) in smallest light curtain profile cross section available (15mm X 20mm)

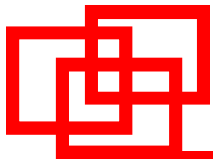

GUARDSHIELD CASCADEABLE MICRO 400



- ON / OFF functionality with MSR42 Controller “Out of Box” configuration
- Cascadeable Micro 400 Outputs are data only, functionality is through controller
- Cascadeable Micro 400 Environmental Rating: IP 54
- GuardShield Micro 400 cascaded system with MSR42 Controller is rated SIL3_{CL} per IEC 61508, PLe per EN13894, cULus listed and CE marked.
- Operating Temperature 0 to 55°C
- 940nm wave length
- Very small profile (15mm X 20mm) with integrated 20 inch pigtail cable and 8 pin M12 connectors
- A pair of dedicated patch cords are required to connect the integrated pigtail cable M12 connectors to the RJ45 connections of the MSR42
 - Same part number for transmitter and receiver patch cords
 - Offered in 3M, 5M & 8M lengths (445L-AC8RJ3, 445L-AC8RJ5, 445L-AC8RJ8)

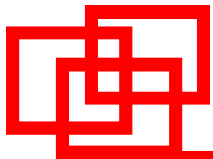

WHAT IS CASCADING?

- Cascading is a term that refers to the ability of safety light curtain segments to be interconnected resulting in a single pair of outputs (OSSD's).
- A common configuration of cascaded light curtains is a single pair of light curtains mounted vertically at the required safety distance and a horizontal segment pair located between the vertical light curtain and the hazard. It is necessary to prevent reaching over, under or around the safety light curtains to gain access to the machine hazard
- Although up to 3 segments may be interconnected in a Micro 400 Cascadeable system, there is a maximum number of beams which limits the number of segment configurations
- Cascaded segments can be of mixed resolutions and protective heights
- Supplemental safeguarding is usually required to prevent access to the machine hazard.

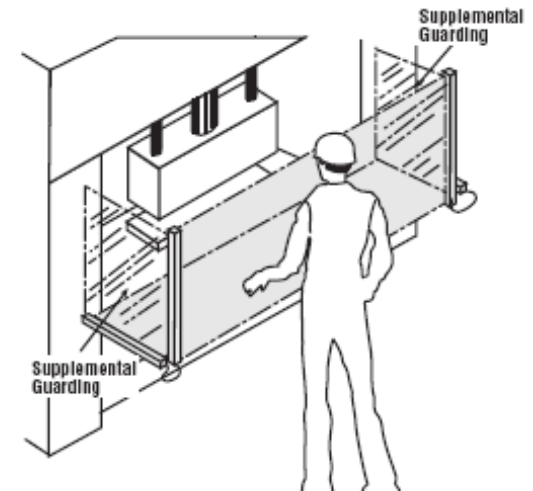

The maximum number of beams allowed in a Cascaded GuardShield Micro 400 system is 255 beams.

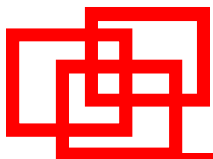

MSR42 – GUARDSHIELD MICRO 400 CONTROLLER / MULTI FUNCTION SAFETY MODULE

- Safety Controller for GuardShield Micro 400
- ON / OFF “out of the box” functionality
- Cat 4 EN954-1, SIL3_{CL} EN IEC 61508
- Auto / Manual Reset – Configured through wiring
- 2PNP outputs (400mA 24Vd.c.)
 - Can add safety relay outputs by connecting up to three MSR45Es
- Response time 5ms
- Software Configurable – requires an Optical Interface to configure
 - EDM (Feedback loop) for monitoring external actuators
 - Configuration of 4 inputs and two outputs
- Additional inputs for
 - Muting sensors (2 or 4)
 - Light curtains: GuardShield Safe4, GuardShield, GuardShield PAC
 - SafeZone Safety Laser scanner
 - E-Stop
 - Safety switches
- Muting
 - 2 and 4 sensors with Micro 400
 - 2 Sensors with Safe4 or GuardShield Original
- No blanking at initial launch

**Connect the suction cup
to the MSR42 to configure**



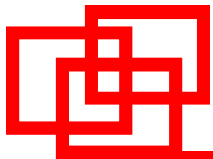

MSR42 & MSR45E

MSR42

- Default configuration to work out-of-the-box
 - Can be changed by external wiring:
 - Manual / Auto restart
- Default configuration can be changed by software to access additional functions

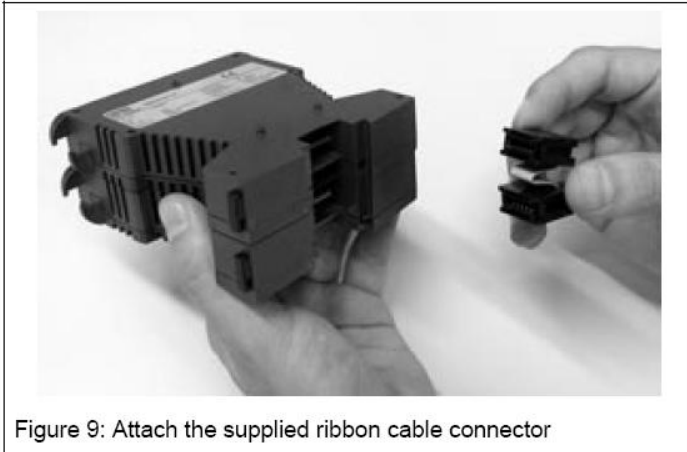
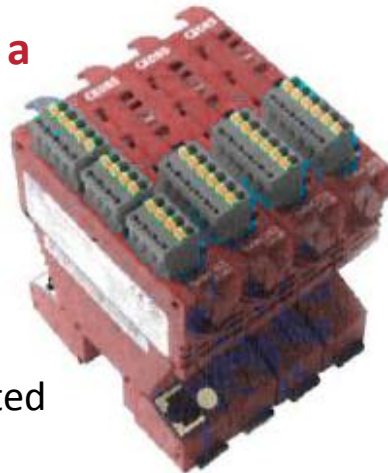

Figure 9: Attach the supplied ribbon cable connector

MSR45E – Expansion Module - Not a stand alone safety relay module

- 2NO Safety relays
- 6A contacts with one 45E
- 4A with two or more 45E
- Up to 3 extension modules connected MSR42
- Auxiliary output on MSR42 base (configurable)
- **The units snap together, and a ribbon cable in the base provides the electrical connections.**



440R-ACABL1



440R-ACABL2



440R-ACABL3



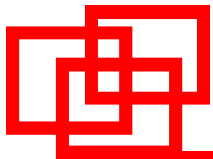

MSR 42 - MICRO 400 CONTROLLER

- Multi Function safety module
- Software configurable operating modes
 - 2 and 4 Sensor Muting with One set of Micro400 light curtains
 - Two sets of light curtains (Micro 400 and one other) – only 2 Sensor muting possible
 - Three sets of light curtains – 1 must be GuardShield Micro 400
 - Integration of a two channel E-Stop or Interlock Switch

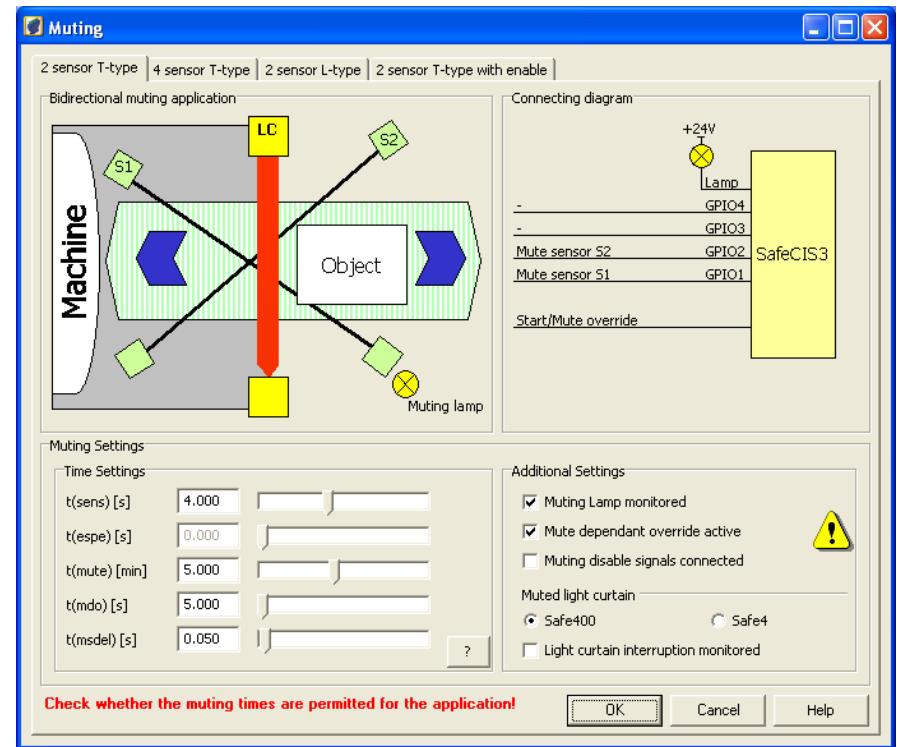

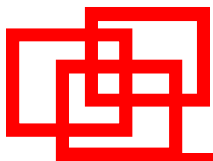

GUARDSHIELD MICRO 400 WITH MSR42 – MUTING FUNCTIONS

- Different types of muting can be configured (2 and 4 sensors)

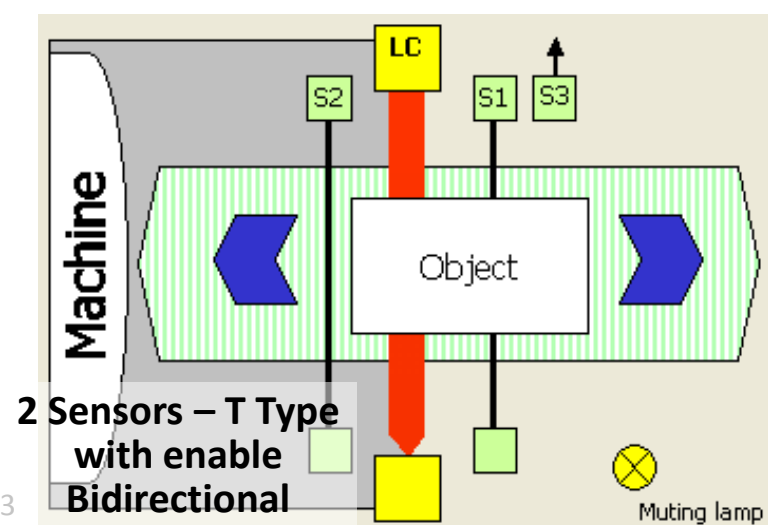
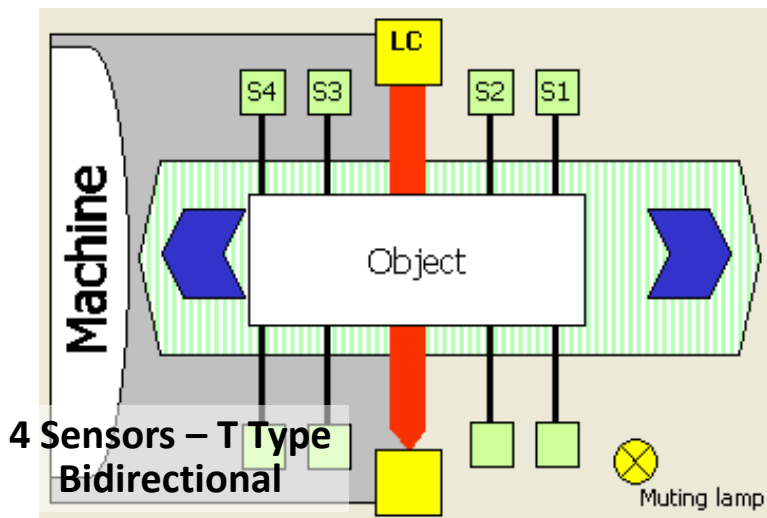
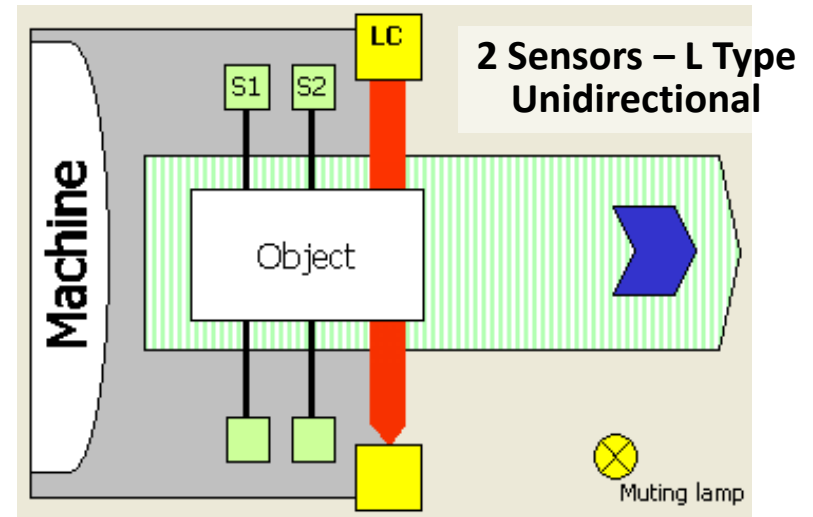
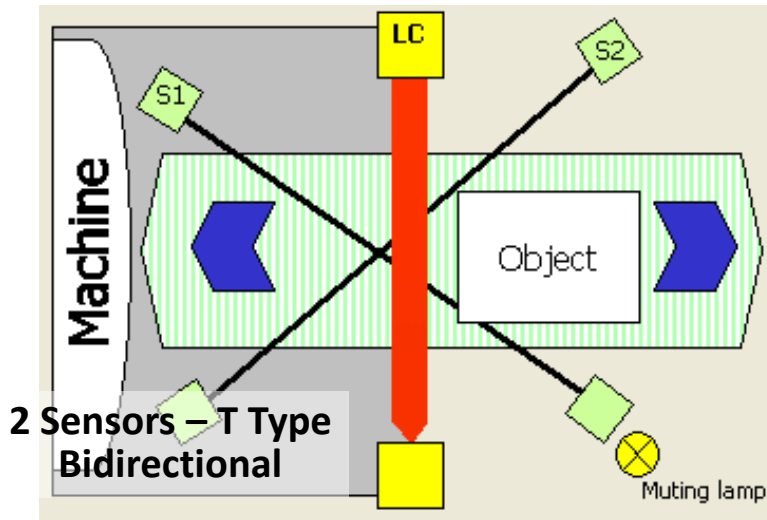

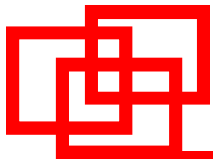

MSR42 – MULTI-FUNCTION SAFETY RELAY MODULE

Components that can be connected to the MSR42

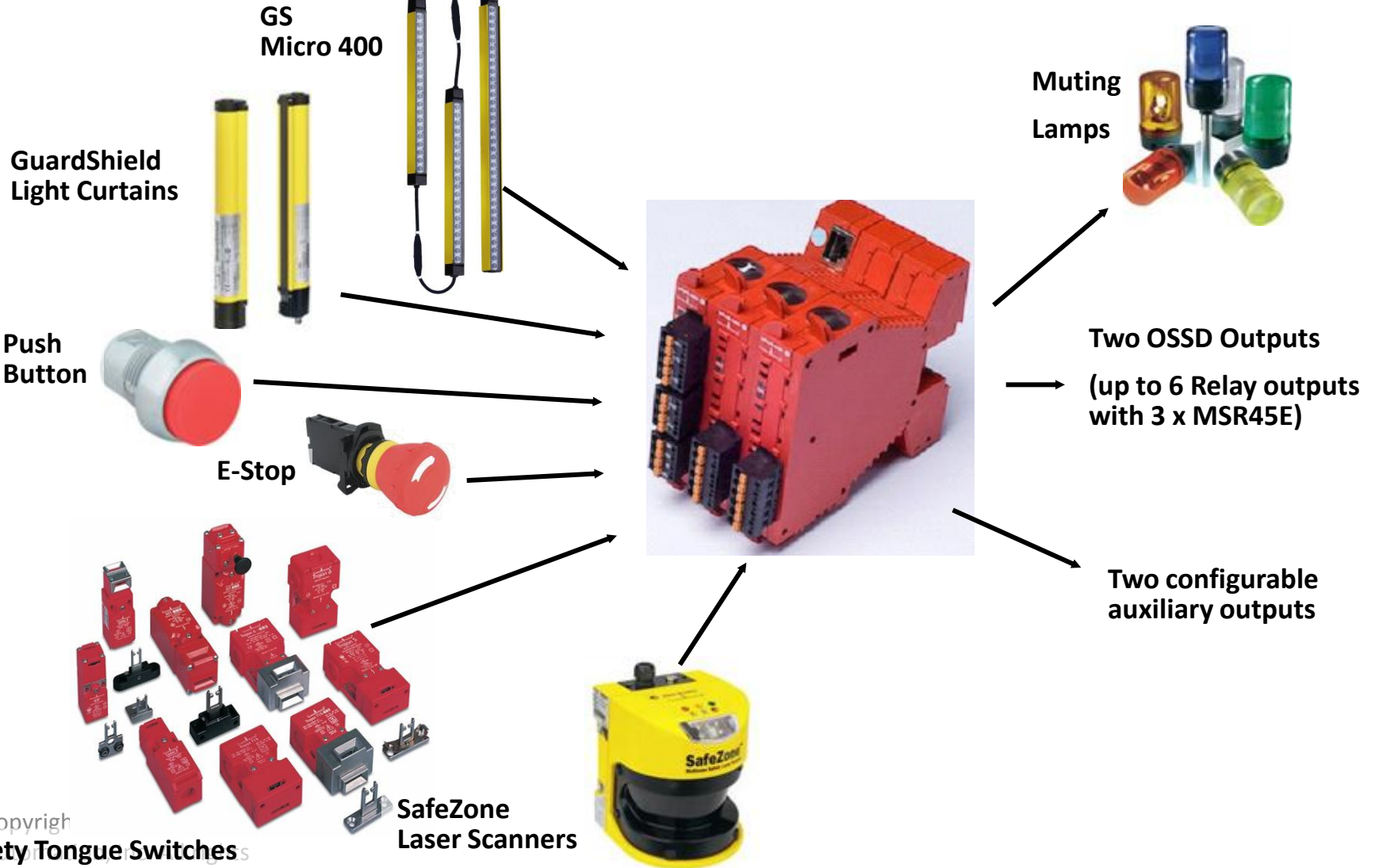

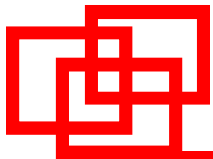

GUARDSHIELD SAFE 4 INTEGRATED ALIGNMENT



- Powered Class 2 visible laser beams located at the top and bottom of each light curtain pair.
- Simply touching the finger symbol on the face of the transmitter and receiver activates each alignment laser
- Visible laser stops transmitting after finger symbol is retouched - or automatically ceases transmitting after 5 minutes
- Used to ease alignment at installation or during the course of production if knocked out of alignment during operation

The Integrated Laser Alignment System provides quick and easy alignment

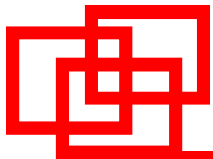

GUARDSHIELD SAFE 4 LASER ALIGNMENT

Patented Laser Alignment System

- Simply touching the laser area activates this visible Class 2 laser,
- The laser is turned on, and alignment can be achieved quickly, without the need for additional devices
- Each visible laser has a target opposite of it to facilitate optimal alignment

Integrated Laser

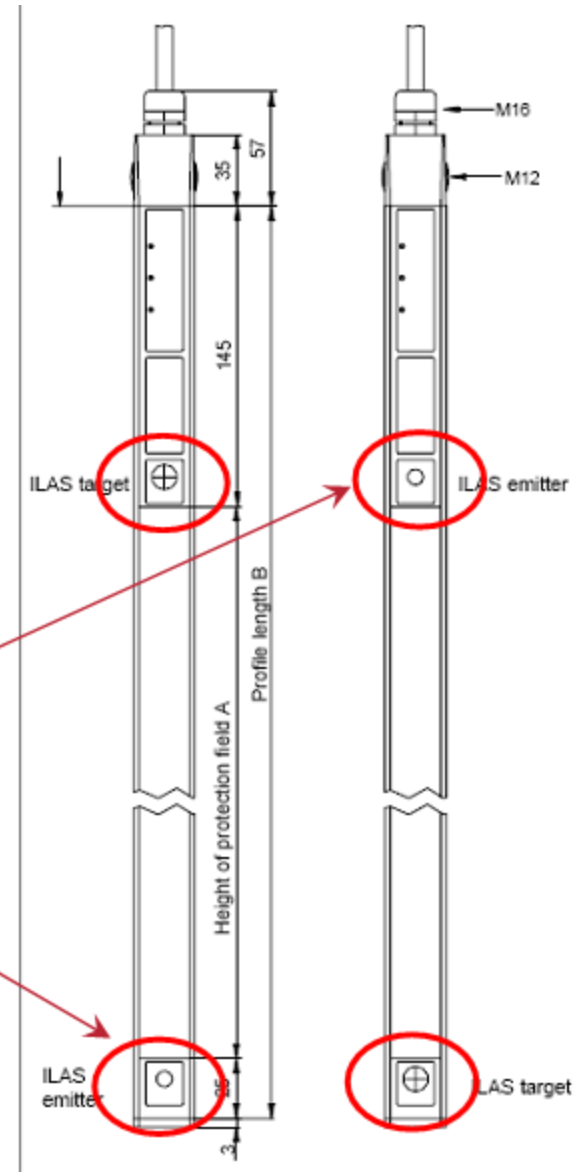

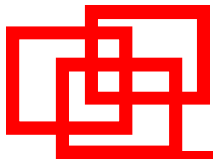

GUARDSHIELD SAFE 4 PAC INTEGRATED LASER ALIGNMENT



- Class 2 visible laser beams located at the top and bottom of each light curtain pair.
- Simply touching the finger symbol on the face of the transmitter and receiver activates each alignment laser
- Visible laser stops transmitting after finger symbol is retouched - or automatically ceases transmitting after 5 minutes
- Used to ease alignment at installation or during the course of production if knocked out of alignment during operation

The Integrated Laser Alignment System provides quick and easy alignment

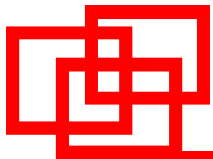

TYPICAL CORNER MIRROR APPLICATION

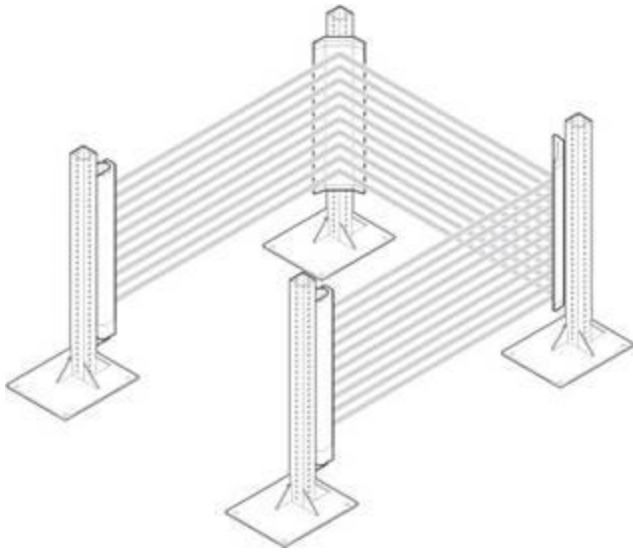

Typical 3 sided guarding application using 440L-AMSTD mounting stands and GuardShield POC safety light curtains.

Typical three-sided guarding application using 440L-AMSTD mounting stands and GuardShield PAC safety light curtains

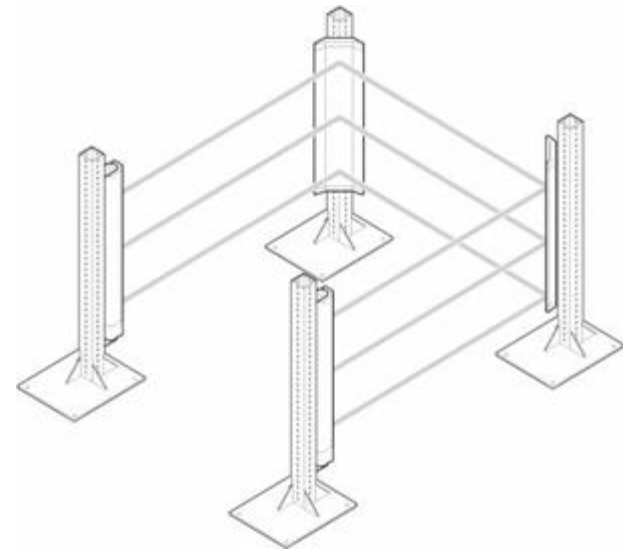

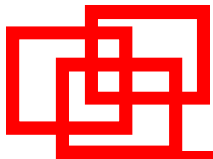

GUARDSHIELD CASCADING

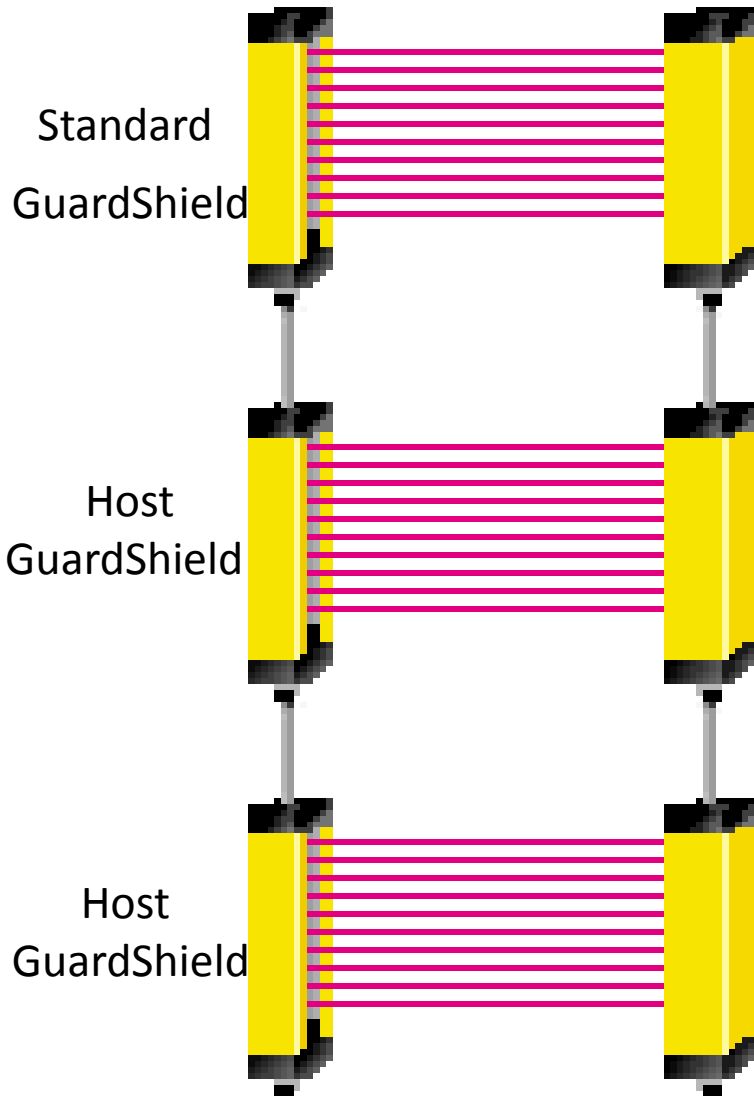

- Maximum of 3 pair of 1760mm GuardShield interconnected with a common pair of outputs (same OSSDs as a standard pair of GS)
- Maximum patch cord length between segments is 2 meters
- Able to configure each pair separately,
 - Host functionality (Beam coding, EDM, Start / Restart interlock, Fixed / Floating Blanking)
 - EDM and Start / Restart not allowed in middle or end pairs
- Mixed resolutions (14mm and 30mm) can be interconnected.
- Response time is not affected by the Cascaded system. The longest response time of any configured pair in the system is the system response time.

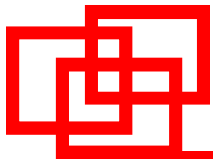

GUARDSHIELD WASHDOWN ENCLOSURES



- Kits offered from 320mm to 960mm protective heights
- 10% loss of operating range
- Assembly procedure must be followed to assure proper sealing of enclosures.
- Dis-assembly procedure must be followed to prevent damage to GuardShield endcaps.
- GuardShield Type 2 should not be used with these enclosures due the effect of increased optical dispersion of the Infrared light.

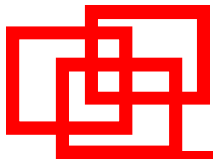

WASHDOWN ENCLOSURE KIT

- Each Kit contains;
 - Two acrylic tubes
 - Two top acetal endcaps
 - Two bottom acetal endcaps
 - Two acetal spacers
 - 4 Stainless endcap mounting brackets
 - 4 viton O-rings
 - Two cord grip assemblies
 - Two black Poron foam spacers

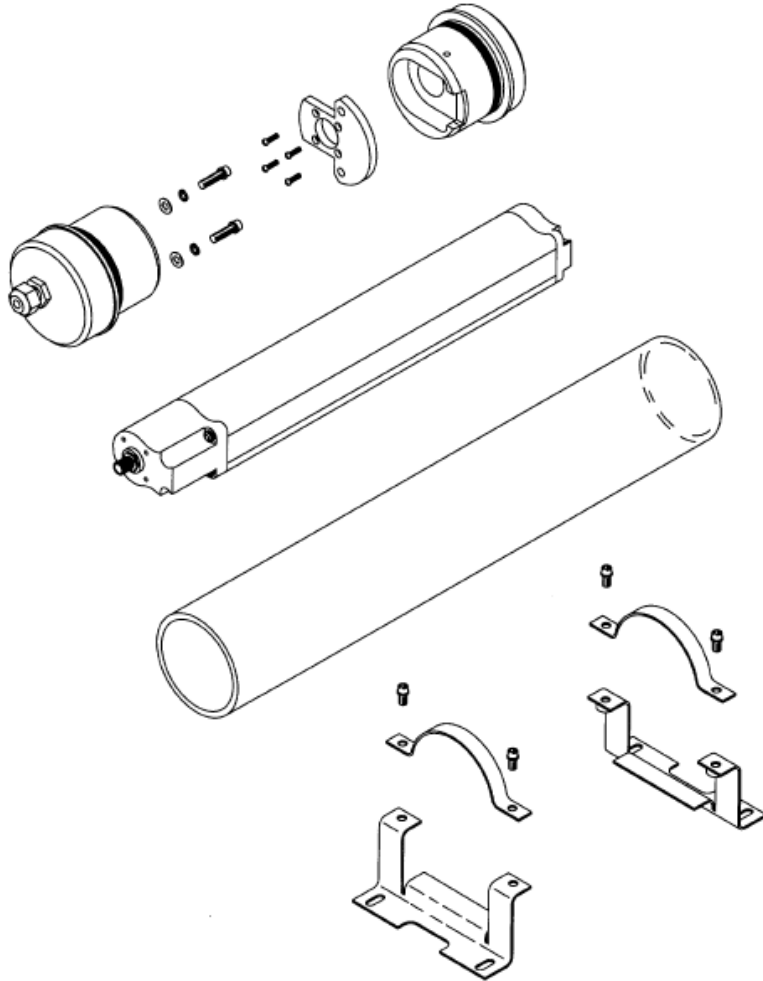

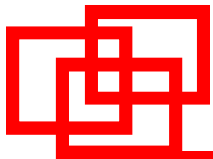

MSR300 SAFETY SYSTEM

- The modular MSR300 system offers the ability for a logic configuration with multiple inputs and control of multiple independent outputs (up to 3)
- Output modules for three groups (zone control)
- Each input module can be configured to switch one or more output groups
- Special bypass functionality for controlled access (e.g., in robot cells)
- Cat.4 EN 954-1, SIL3 IEC 61508 approvals



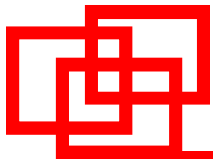

MSR300 MODULES

- **Input module MSR320:**

- Up to 10 modules per base
- 2 configurable inputs per input module
- 1 auxiliary solid state output per input (Channel)
- One set of rotary switches defines the type of input device(s) connected
- One set of rotary switches defines which output group the input module controls

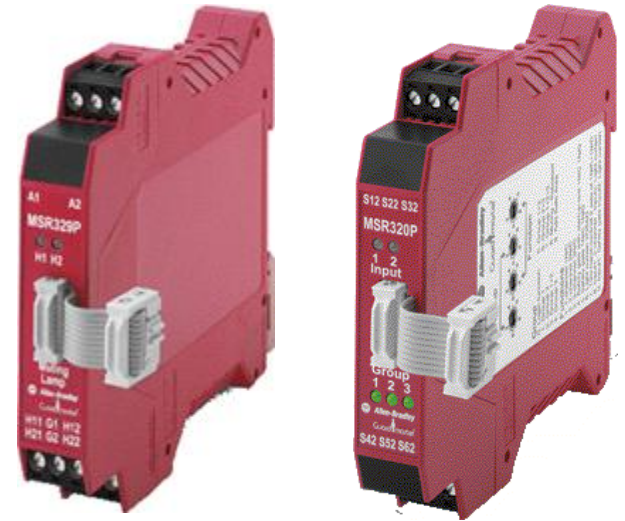

- **Input module MSR329:**

Muting lamp control module, for 2 muting channels

- **Controller module MSR310:**

Dual processors control I/O modules and provide extensive diagnostic information via various interfaces and solid state outputs

- **Output module MSR330:**

- Maximum of 6 output modules can be connected to each base module (18 N.O. + 6 N.C.)
- Maximum of three output groups available for independent control



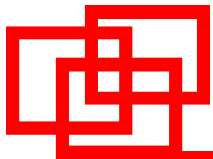

CONTROLLER MODULE MSR310

- Setting of the start function groups : monitored / auto reset
 - Each group configured separately
- Independent feedback loops for each group
- 3 solid state outputs indicate which group is active
- Integrated diagnostic interface – monitoring only
 - RS232 (Available today)
 - DeviceNet (Available Aug 06)
- Extensive bi-colored LED diagnostics
- 35mm enclosure with plug-in connection terminals (screw type)
- No inputs / no safety outputs



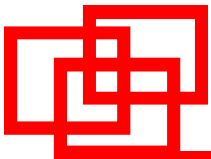

INPUT MODULE MSR320

- 2 inputs for single-, dual- or three-channel activation
- Four 10-step rotary switches on the enclosure side:
 - One set for the group selection
 - One set to configure inputs type
- Selectable “Start-up Test” function
- Light curtain (solid state) and/or safety switch (contact) inputs in one module
- 17.5mm enclosure with plug-in connection terminals (screw type)
- Annunciation for each input connected (24V DC solid state output)



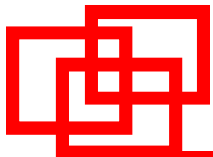

INPUT CONFIGURATION MSR320

- Configuration of both inputs by “Select Function” switches (both channels must be set on the same value)
 1. One-channel E-stop
 2. Two-channel E-Stop or safety mats
 3. Three-channel E-Stop
 4. Safe gate (N.O./N.C.) with start up test
 5. Safe gate (N.O./N.C.) without start up test
 6. Light curtain (both Inputs)
 7. Two-Hand operation
 8. Channel 1: Two channel E-Stop
Channel 2: Light curtain
 9. Channel 1: Safety gate
Channel 2: Light curtain

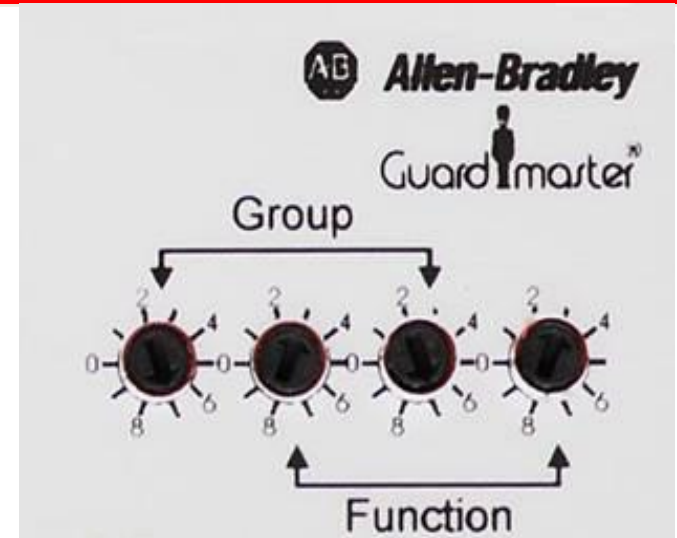

Group

- | | |
|-------------------|-----------------------|
| 0. Logic function | 5. Group 1+3 |
| 1. Group 1 | 6. Group 2+3 |
| 2. Group 2 | 7. Group 1+2+3 |
| 3. Group 1+2 | 8. Muting - Robotcell |
| 4. Group 3 | 9. Add Safe Area |

Function

1. 1-channel 1N/C
2. 2-channel 2N/C, Safety Mat
3. 3-channel 3N/C
4. Safety gate with startup-test 1N/C 1N/O
5. Safety gate 1N/C 1N/O
6. Light curtain 2OSSD
7. Two-hand control 2 sets of 1N/C+1N/O
8. Input1: 2-channel Input2: Light curtain
9. Input1: Safety gate Input2: Light curtain

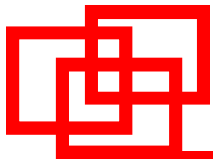

GROUP SELECTION MSR320

- **Group Selection by “Select Group” switches (both channels must be set on the same value)**
0. Logic function
 1. Group 1
 2. Group 2
 3. Group 1+ 2
 4. Group 3
 5. Group 1+ 3
 6. Group 2+ 3
 7. Group 1+ 2+ 3
 8. (Input 1 or Group 1) & (Input 2 or Group 2) = Group 3 (Muting with cross control)
 9. ((Input 1 or Group 1) & (Input 2 or Group 2)) or Input “Safe Area” = Group 3 (Meaning: Inputs are closed or Group1/2 is activated, etc. = activation of Group 3 to run the machine)

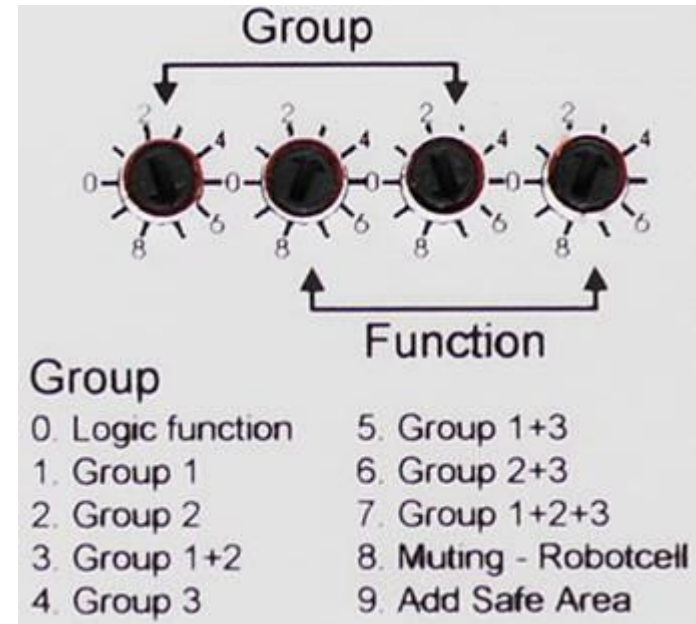

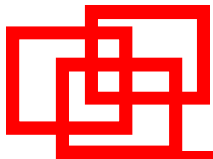

OUTPUT MODULE MSR330

- 4 safety relay outputs, 3 N.O., 1N.C.
- Different catalog numbers depending on group number desired (1, 2, 3)
- Diagnostic status LEDs per channel
- 22.5mm enclosure with plug-in connection terminals (screw type)



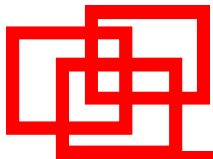

SMARTGUARD 600 WITH ETHERNET/IP

- EtherNet/IP for standard communications
 - NOTE: Standard communications only
 - Connection to Standard PLC, HMI, Programming
 - No support for CIP Safety
 - Supports BootP or static IP addressing
 - Pass-Through support for configuration of DeviceNet modules
 - Distributed I/O with Guard I/O on DeviceNet
- Same functionality as current SmartGuard 600
 - 16 Safe In, 8 Safe Out, 4 Pulse Test Circuits
 - USB port
 - DeviceNet for Safety I/O
- Requires RSNetworx for DeviceNet (v9.x)

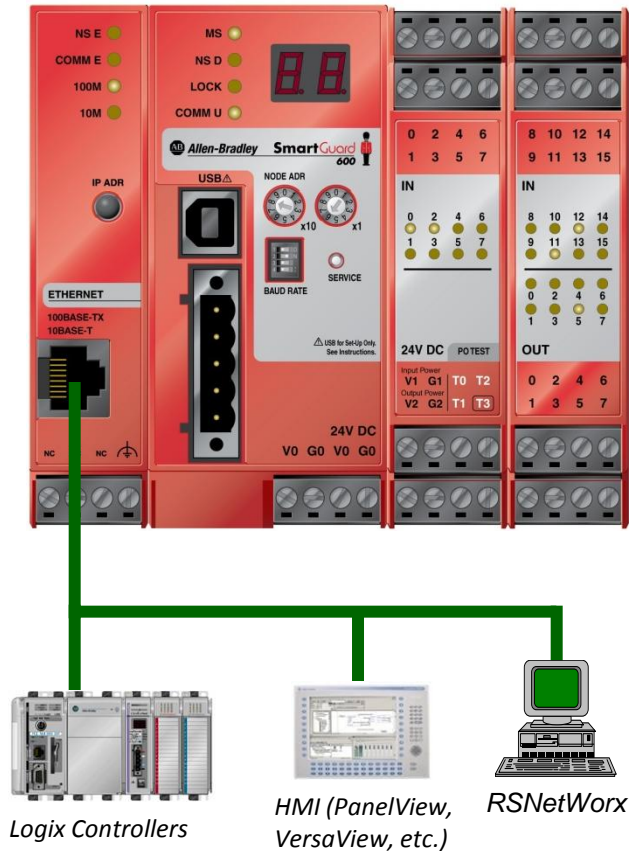

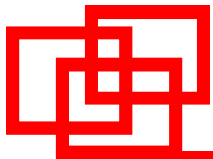

SMARTGUARD ETHERNET/IP CAPABILITIES

- Programming – From PC on Ethernet
- Interlocking – between standard PLC & SmartGuard
- HMI Display – Diagnostic data about safety system
 - Which gate is open, which E-stop is pressed, ...)

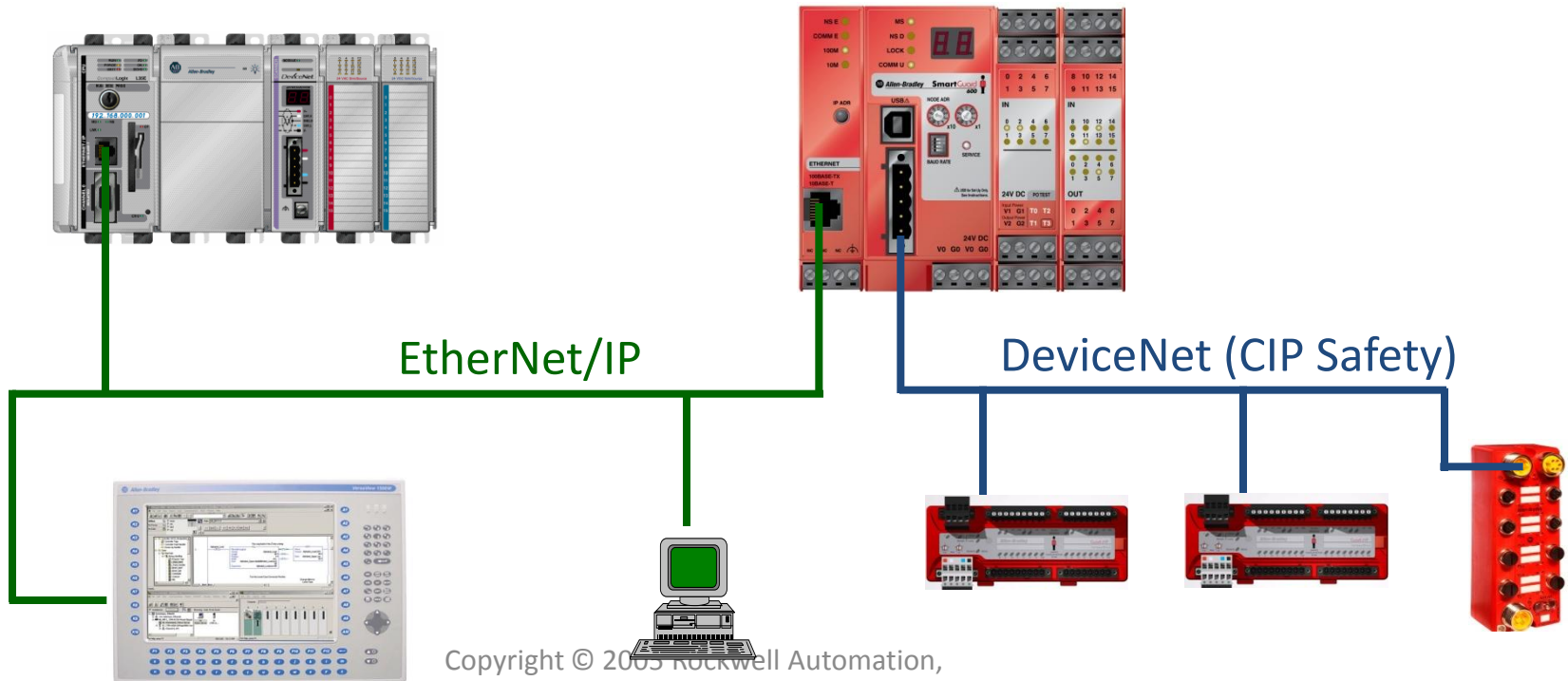

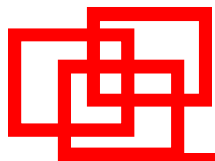

PROGRAMMING IN RSNETWORX

- Programs via editor launched from within RSNetWorx
 - Uses RSNetWorx to configure DNet
- Simple function block programming
- Program can be as large as 254 function blocks across 32 pages
- Drag-and-drop function blocks as well as connections between function blocks

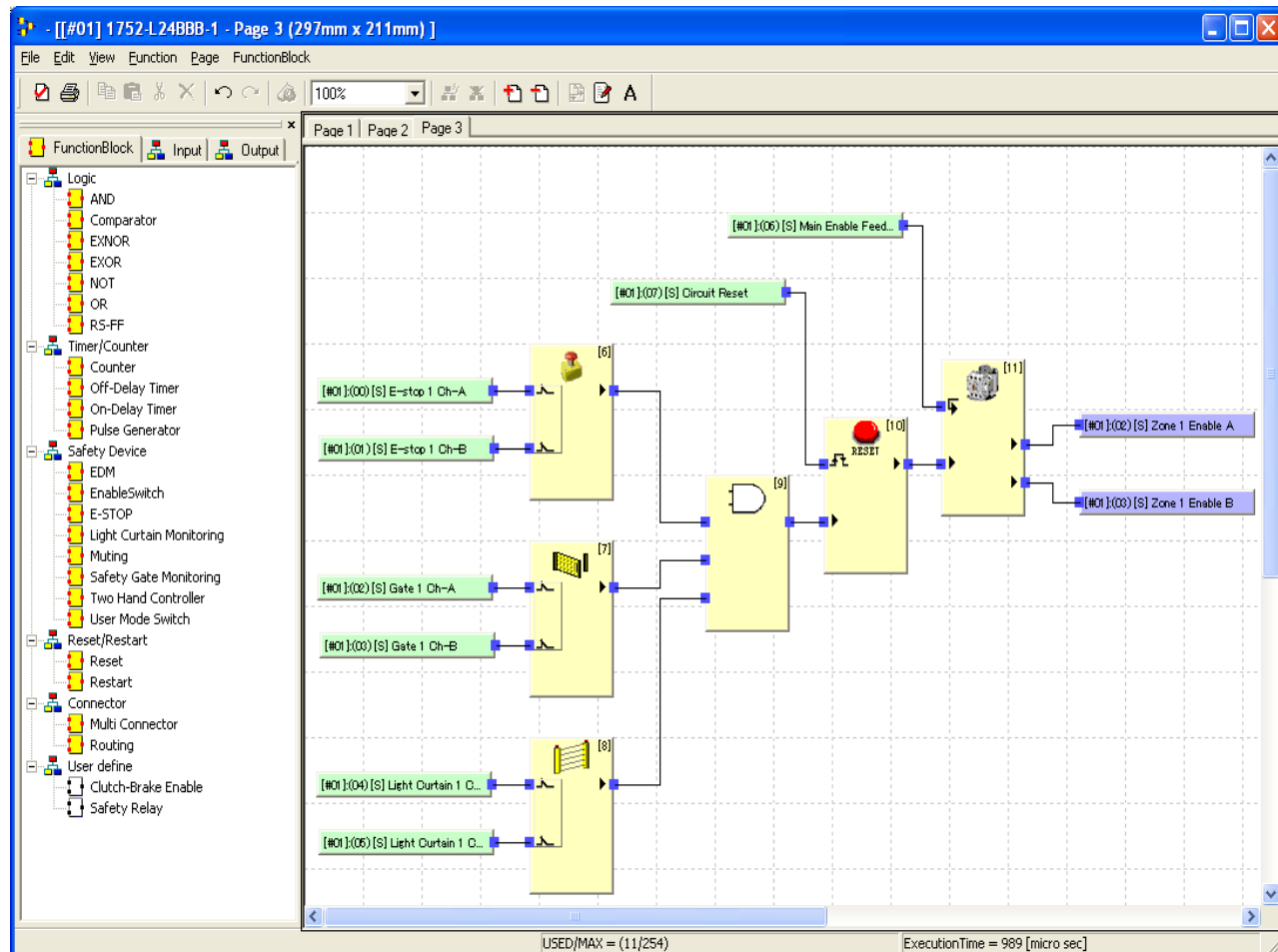

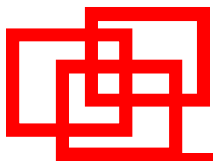

PROGRAMMING – FUNCTION BLOCKS

- Choose from 23 function blocks
- Expand the number of inputs and outputs for certain blocks

OR Block

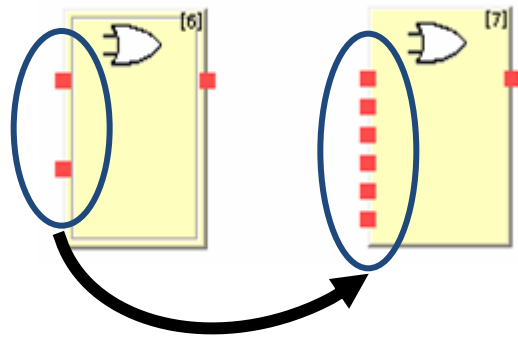

Safety Gate Block

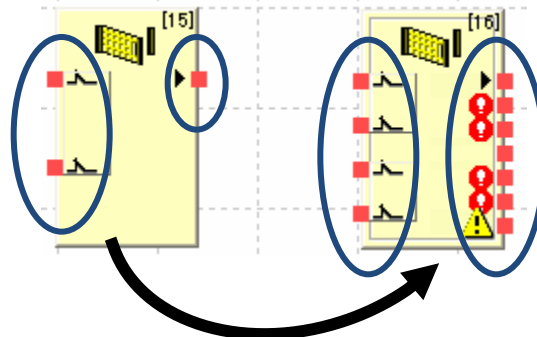

- Simple to use, yet powerful enough for complex safety applications like zone control and distributed safety control

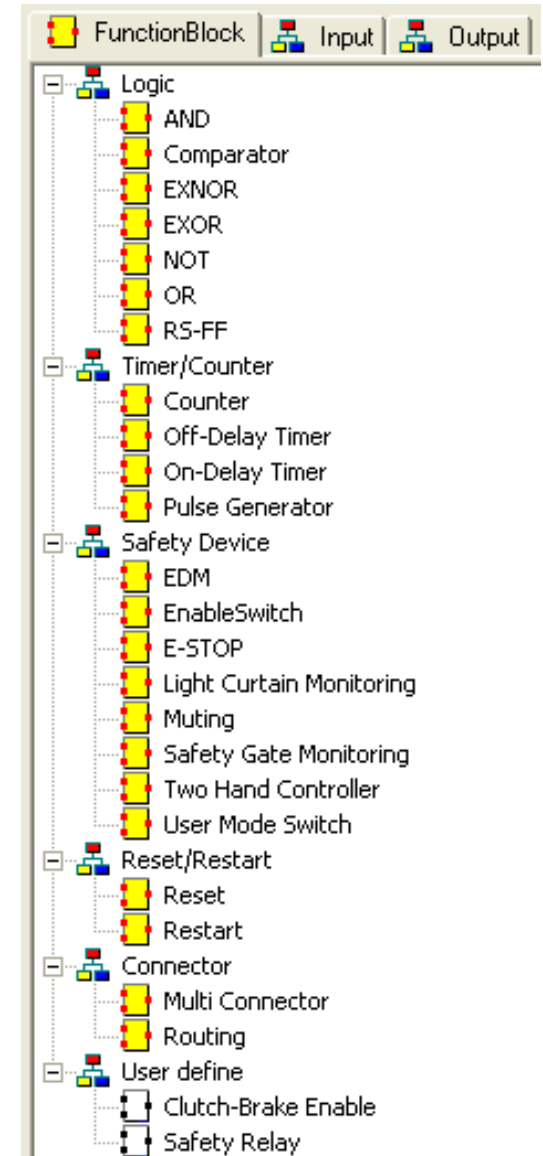

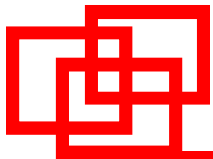

CREATE USER-DEFINED FUNCTION BLOCKS

- Create your own function blocks
- Simple to re-use in same application or in multiple applications
- Makes programs easier to read & understand
- Blocks can be “Validated” and locked. Any change will invalidate the block.

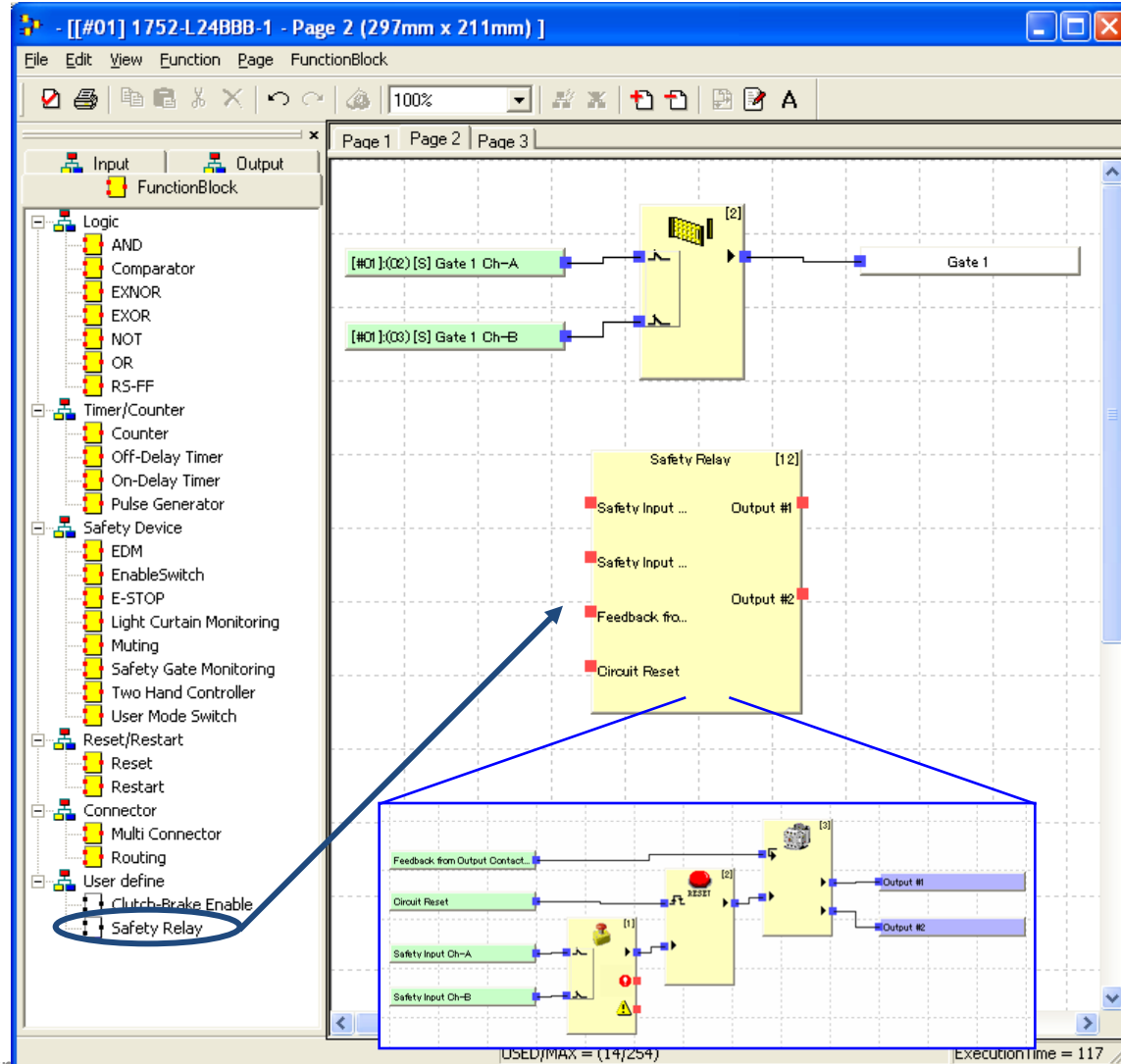

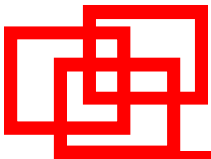

THREE CURTAIN MUTING EXAMPLE

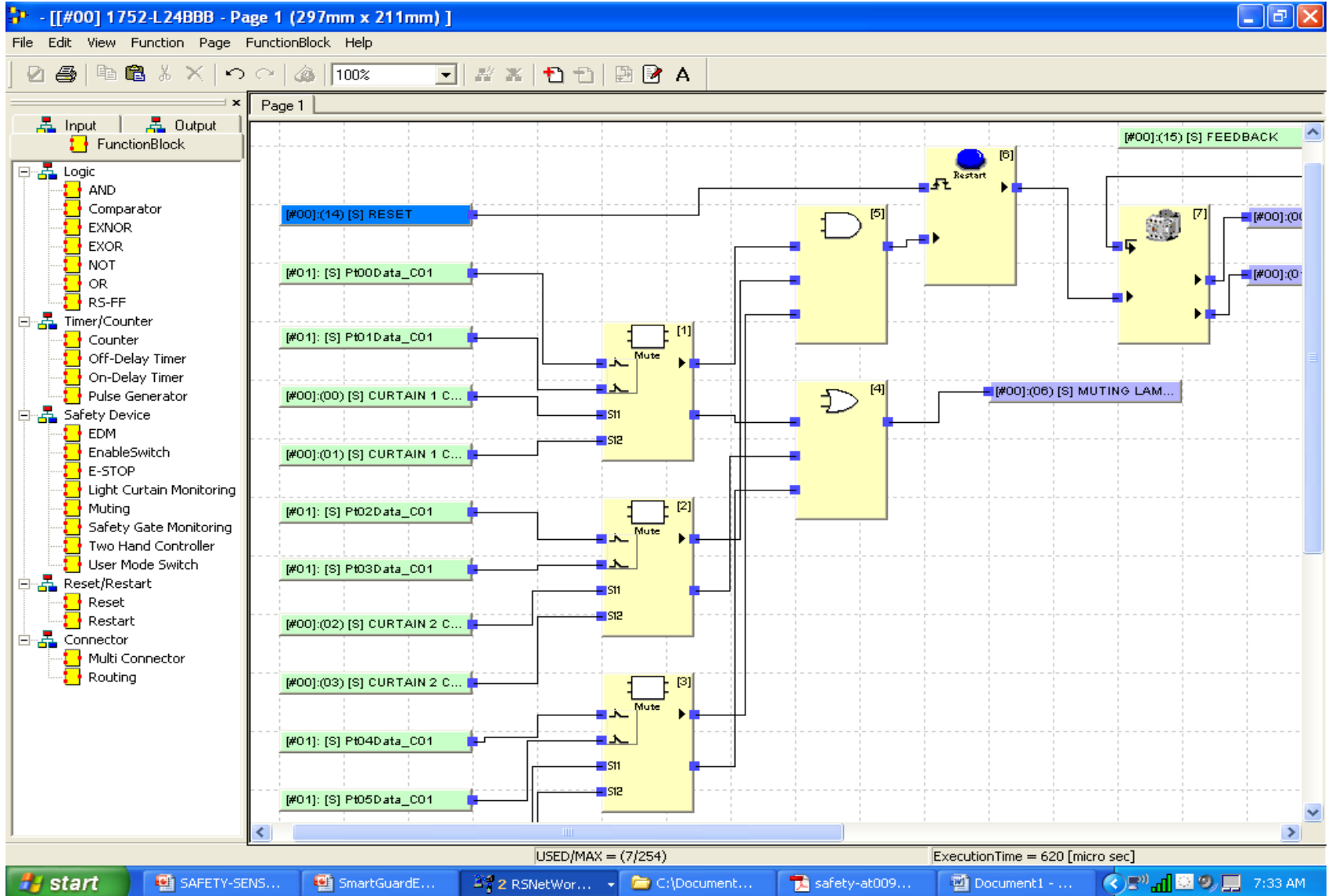

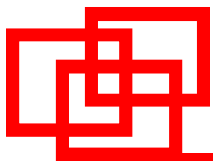

SMARTGUARD 600 SAFETY APPLICATION EXAMPLES

Safety Application Example

Laser Scanner Protection for Automated Conveyor Car Using SmartGuard 600 Packaged Safety Controller

Safety Network-enabled Example
 Safety Rating: Category 3 according to EN954-1



Topic	Page
Introduction	1
Important User Information	2
General Safety Information	3
Description	3
Setup and Wiring	3
Configure the Laser Scanner	3
Programming	11
Performance Data	20
Additional Resources	28

This application example describes a safety movement of an automated conveyor car. Located at the front and back of the car, the scanners detect the path and issue a stop command to the drive if the sensors are connected to a SmartGuard 600 packaged safety controller, which sends signals to the control system.

Safety Application Example

Using SmartGuard 600 Packaged Safety Controller as Standard Slave Connection to CompactLogix Controller

Safety Network-enabled Example
 Safety Rating: Category 4, according to EN954-1



Safety Application Example

Using SmartGuard 600 Packaged Safety Controller as Standard Slave to MicroLogix 1500 Controller

Safety Network-enabled Example
 Safety Rating: Category 4, according to EN954-1



Introduction	1
Important User Information	2
General Safety Information	3
Description	3
Example Bill of Materials	3
Setup and Wiring	3
Configure	4
Programming	11
Additional Resources	18

This example shows how to wire, configure and program a SmartGuard 600 packaged safety controller as a DeviceNet standard slave to a MicroLogix 1500 controller.

Safety Application Example

Dual-zone Safety Gate Protection and E-stop Control Using SmartGuard 600 Packaged Safety Controller

Safety Network-enabled Example
 Safety Rating: Category 4, according to EN954-1



Introduction	1
--------------	---

Safety Application Example

Bidirectional Muting Control of Light Curtain Using SmartGuard 600 Packaged Safety Controller

Safety Network-enabled Example
 Safety Rating: Category 4, according to EN954-1

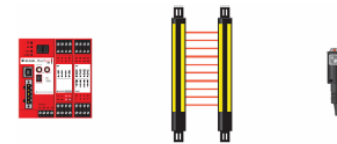

Introduction	1
Important User Information	2
General Safety Information	3
Description	3
Example Bill of Materials	5
Setup and Wiring	5
Configure	6
Programming	12
Performance Data	20
Additional Resources	21

This example describes how to set up, wire and program a SmartGuard 600 safety controller for use with a light curtain in a bidirectional muting application. The typical application would be in an environment where there is motion of material into and out of a guarded safety zone.

Program a SmartGuard 600 safety controller for use with two safety gates and safety limit switches.

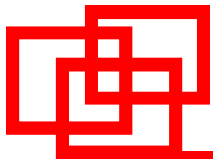

INTRODUCING POINT GUARD I/O

- The POINT I/O platform has now increased in value with it's integration of safety
- POINT I/O provides you the high density and granularity to cost optimize your design and most closely fit your application's I/O requirements
 - POINT standard I/O available in 2,4, and 8 point module densities
- POINT Guard I/O safety modules introduced to the portfolio at this time:
 - 1734-IB8S - 8 Point Safety Sink Input
 - 1734-OB8S - 8 Point Safety Source Output
- For use with GuardLogix[®], SmartGuard[™] and Guard PLC[™]
- Combine your safety and standard I/O into one distributed I/O platform



CompactBlock
Guard I/O



POINT I/O

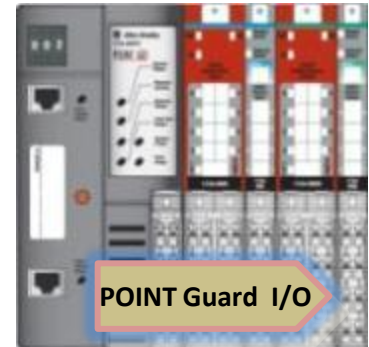

POINT Guard I/O

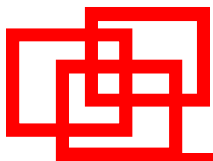

EXAMPLES OF COMBINING POINT SAFETY + STANDARD I/O

- Only ONE network node (one IP address) is required using Ethernet/IP
- You can group modules to optimize I/O functions, tailored to each application
 - Detailed explanations can be found in the POINT Guard I/O user manual
- You can even choose having two controllers communicate to the same node
 - IE: GuardLogix controls the Guard I/O, while ControlLogix controls the standard I/O
 - IE: One ControlLogix rack, with one 1756-ENBT, using one Ethernet/IP cable

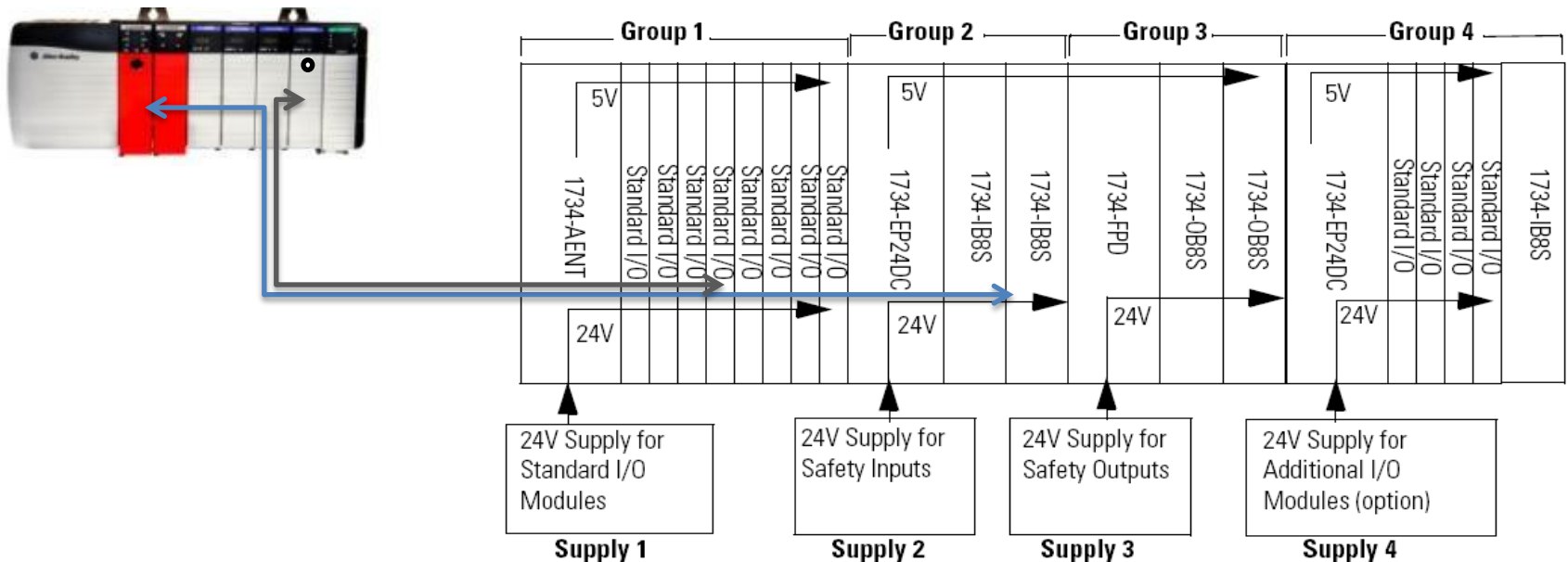

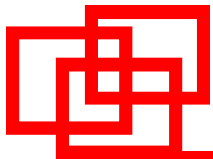

MSR57 SPEED MONITORING RELAY

- **Key Impact**
 - First Rockwell solution for Safe Speed monitoring
 - RA offers more than just Safe Off
- **Main Features supported**
 - SIL3, Cat 4
 - Up to 2 encoders (TTL and Sin/Cos)
 - Safe inputs for Safety component products
 - Utilizes same HIM module and software used for PF70 drives (Drive Explorer and DPI hardware tools)
 - Monitors and controls standard and safety drives
 - Multi-axis applications
 - Door control to prevent access to hazard when unsafe
 - Allows access during safe speed conditions
 - Performs shutdown during over-speed conditions
 - Ideal for new and existing installations
- **Key Applications**
 - Roller Coaster Rides
 - Ski lifts
 - Tire industry
 - Web machines
 - Robot cells



S	N:P:Pr	Name	Value	Units
*	1: 0.1	SS Input Type	Not Used	
*	1: 0.2	SS Stop Type	SS 0 spd ct	
*	1: 0.3	SS Monitor Delay	0.0	Sec
*	1: 0.4	SS Stop Delay	0.0	Sec
	1: 0.5	SS Stop Speed	0.001	rps
	1: 0.6	SS Stop Pos	10	line
	1: 0.7	SS Decel Spd	0	lpr
	1: 0.8	SS Decel Tol	0	%

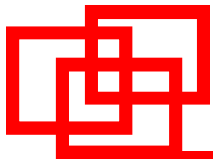

MSR 57 FUNCTIONS

<u>Function</u>	<u>Operation</u>
Safe stop	Initiate Safe Stop (NFPA 79 Category 0, 1, or 2)
Zero speed monitoring	Only allow access (unlock door) when axis is stopped.
Safe limited speed	When requested, monitor speed. If in excess of safe speed, initiate Safe Stop.
Safe maximum speed	Always monitor for safe maximum speed, even under normal operation. If in excess, initiate Safe Stop
Safe direction monitoring	When requested, monitor direction. If wrong rotation direction, initiate Safe Stop
Door monitoring and control	Unlock door to grant access when at safe speed or zero speed.
Enabling switch control	Use in conjunction with Safe Limited Speed. Allow access when at Safe Speed. If no Enable Switch, initiate Safe Stop.
Safe Max Accel monitoring	When configured, if accelerating too fast, initiate Safe Stop.

Cat 4, SIL 3, PLe integrated Safe Torque Off

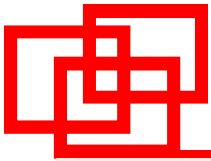

COMING

SOON!!!

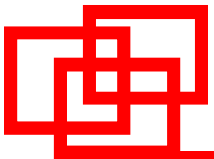

SENSAGUARD – UNIQUE CODED VERSION

Product Description

- Unique coded RFID sensor and actuator
- All models types
- Large sensing range
- Plastic and Stainless Steel housing
- Safety Rating Cat 4 SIL 3

Customer Advantages

- Automatic learn process at unit power up.
- Additional security feature

Competitive Differentiators

- Large product offering
- During commissioning the customer can choose if the sensor can be re-programmed up to 8 times or locked for a one time learn only.

Complete
Family



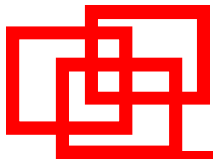

COMMISSIONING - SENSOR CAN LEARN A NEW ACTUATOR 8 TIMES

- **Initially teaching in the actuator**

The sensor will automatically start the learning process as soon as an actuator is brought into the sensing range

- **Learning Sequence – Automatic learn**

Target present: "Status/Diag" LED blinking Green 1Hz rate

Verifying actuator: "Status/Diag" LED blinking Green/RED 1Hz rate (15sec)

Program Sensor: "Status/Diag" LED blinking Green/RED 4Hz rate (15sec)

Program Complete: "Status/Diag" LED blinking Green (# of learns left) (15 sec)

Ready state: "Status/Diag" LED solid Green

Learn is complete



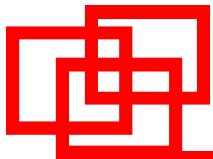

COMMISSIONING - SENSOR CAN LEARN A NEW ACTUATOR 1 TIME ONLY

- **Initially teaching in the actuator**

The sensor will automatically start the learning process as soon as an actuator is brought into the sensing range.

- **During the Program Locking Stage, perform the following steps:**

Remove the actuator from the sensing field, until the "Status/Diag" LED changes to solid Red.

Replace the actuator back into the sensing field and the "Status/Diag" LED will continue blinking Green (# of learns left).

- **Note: The program locking sequence must be completed within the 15 second program locking window.**



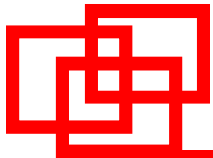

LEARNING A NEW ACTUATOR

Learning a new actuator:

To learn a replacement actuator; bring the actuator to be taught into the sensing range of the safety switch.

The learn sequence is same as the sequence for commissioning the first actuator.

Note:

A sensor can be locked so it can not learn another actuator by removing the actuator from the sensing field during the 15 sec "Program Complete" sequence.

A sensor can not re-learn a previously learned actuator or a standard SensaGuard actuator.

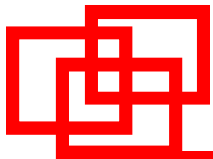

SENSAGUARD LIGHT LATCH

Combination device

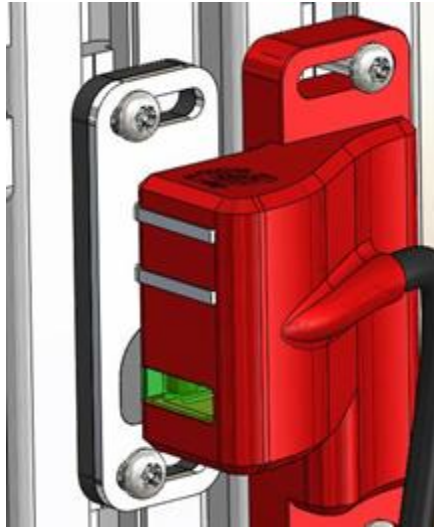

- One device combining a SensaGuard interlock with a magnetic latch
 - Latch force 20-60N adjustable
 - Custom designed for easy mounting on aluminum profile
 - Diagnostic LED
 - IP69K
-
- This new device is perfect for use on framed or unframed lightweight guard doors as used in the food and non-food packaging industry.
 - Save machine build time, only one device to mount
 - All the benefits of the SensaGuard technology
 - Series connection
 - Diagnostics
 - SIL3
 - Non-contact
 - High tolerance to misalignment



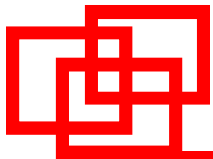

SENSAGUARD LIGHT LATCH

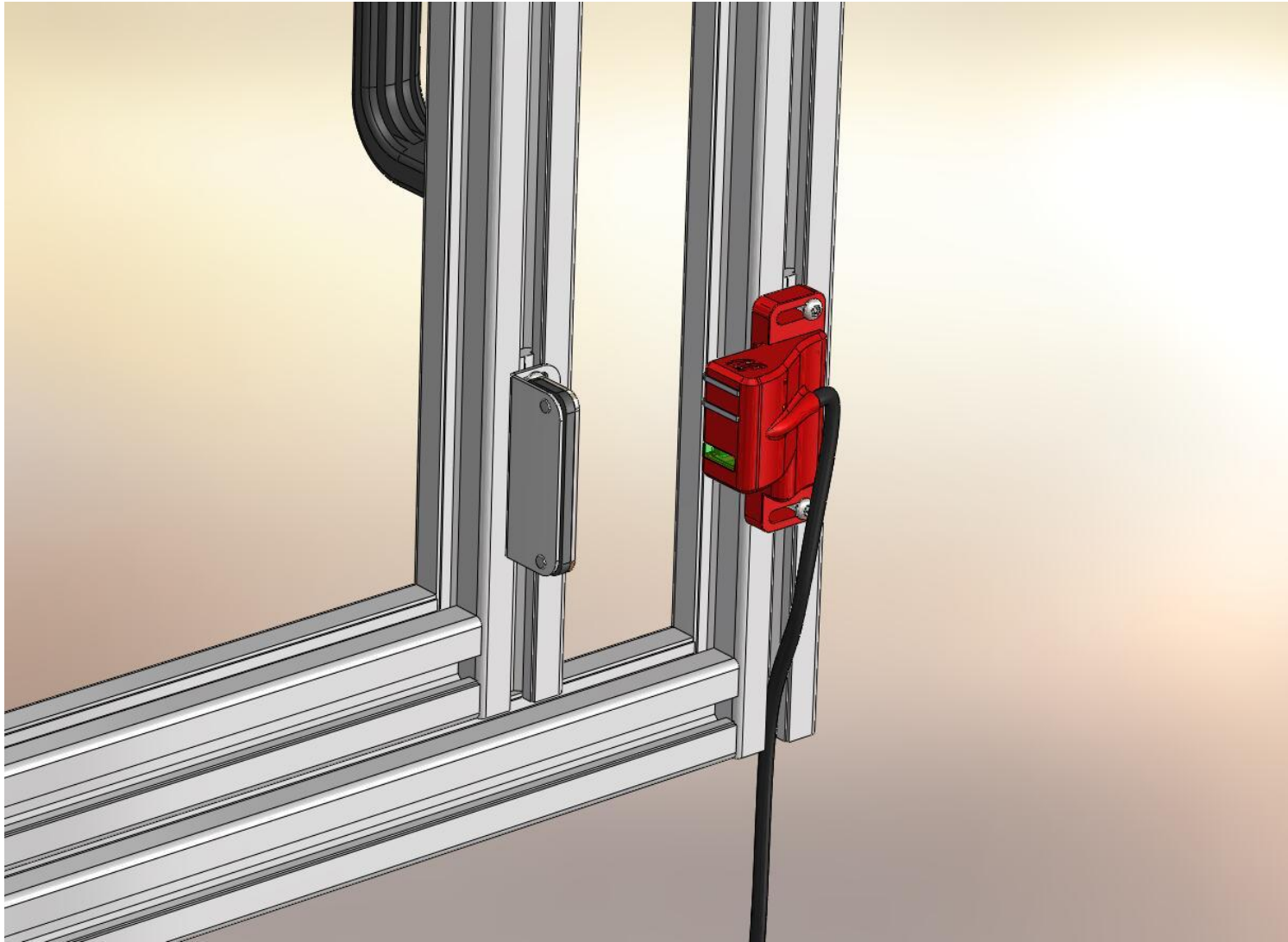

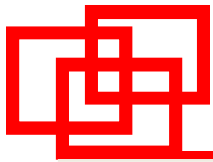

SENSAGUARD LIGHT LATCH

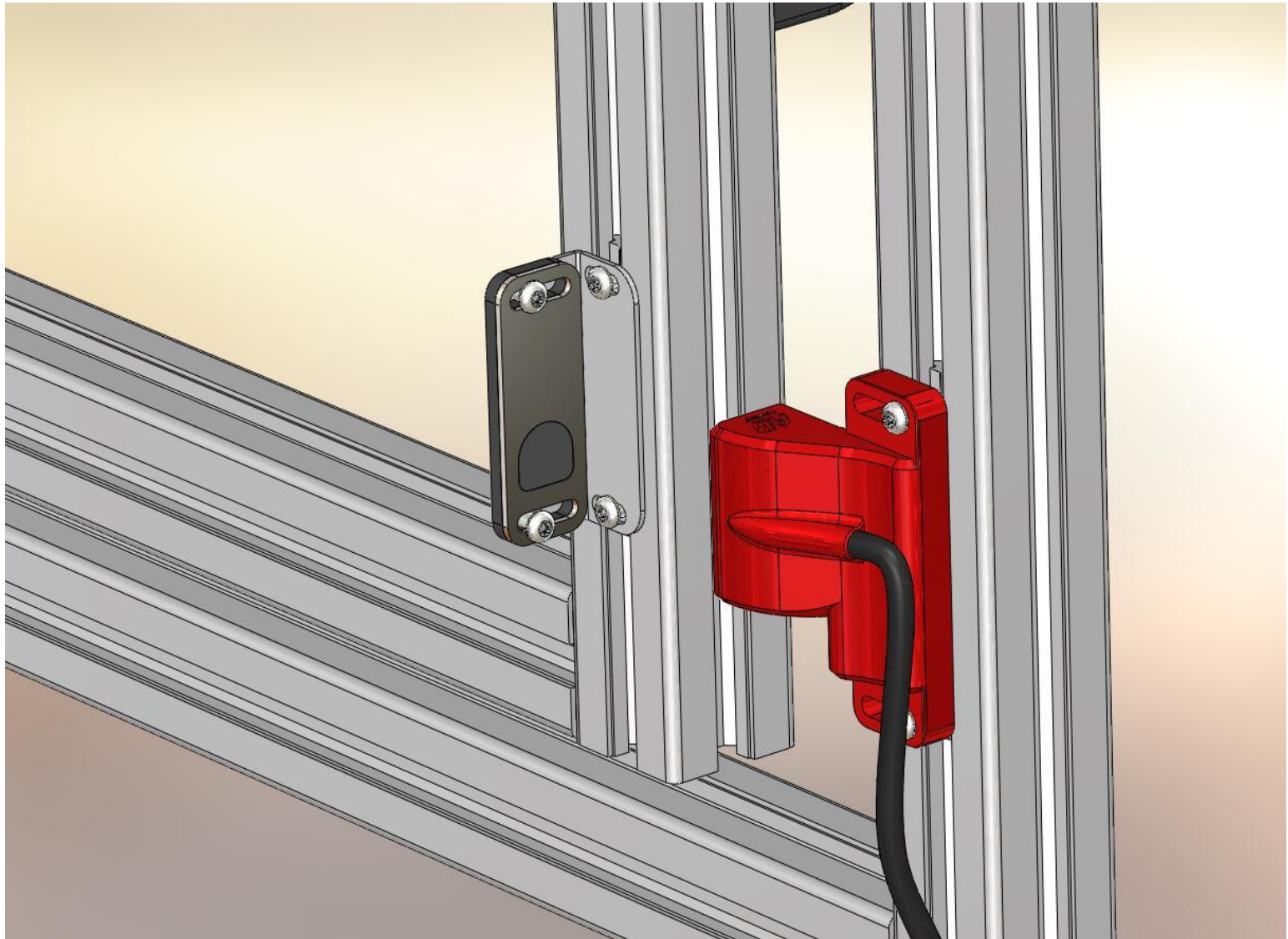

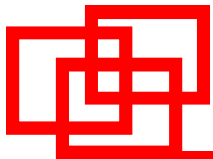

SENSAGUARD LIGHT LATCH

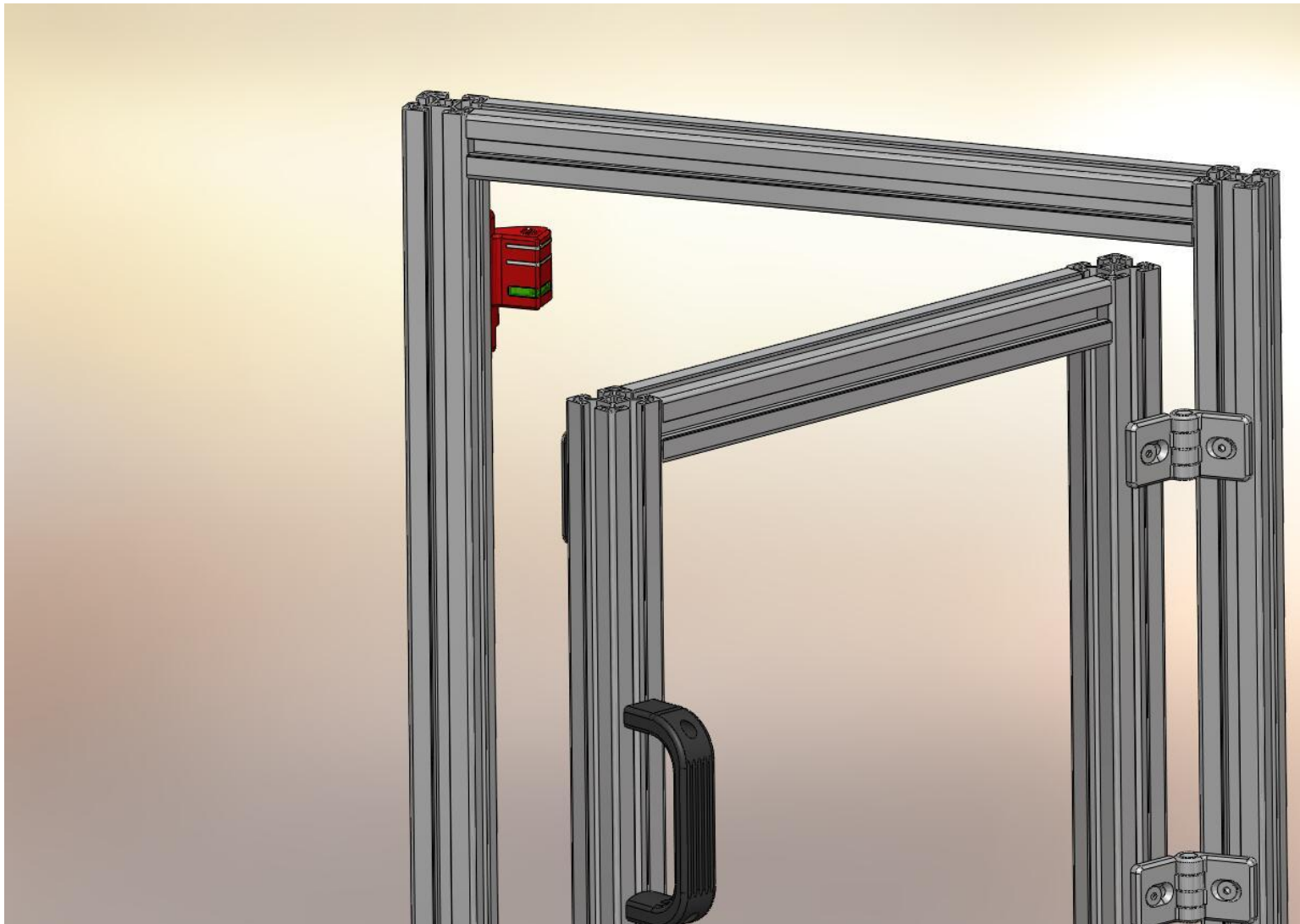

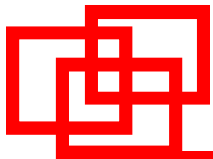

SENSAGUARD — TIMELINE NEW PRODUCT INTRODUCTION

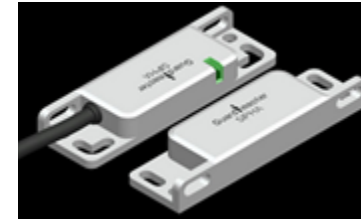

Q2 FY07

Q2 FY08

Q2 FY10

FY10

- Alignment LED
- Magnetic Hold
- Two sensing directions

- Unique codes

- High pressure washdown
- Extended Temperature

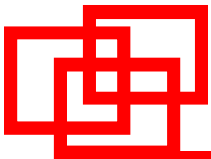

440G-MT 1600N



440G-MT with enhanced diagnostic and true key

- This will have a diagnostic output channel which will enable an auxiliary signal output to “truly” indicate “Door Shut/Door Open” in any operating conditions. Also an LED will display the status of the switch as:-
 - Door open
 - Door closed and unlocked
 - Door closed and locked

Metal manual override key

- A new lid accessory will be available together with a new metal Emergency Override Key (True key)
- This will make the switch more attractive to harsher conditions

Truth Table		Solenoid	
		Energized	De-energized
Actuator Position	In	Step 2 N/C is Open N/O is Closed	Step 1 N/C is Closed N/O is Open
	Out	Step 3 N/C is Open N/O is Closed	N/C is Open N/O is Closed

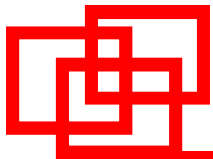

TLS GD2 SERIES E



IP69K “Hot wash down”

- Improves suitability for food processing application

“Free float” in the locked position increased from 2.5 to 4mm

- Improve door misalignment performance
- Improves suitability for machine driven doors
- Improves performance with a door closing against a rubber edge stop.

Matches existing profile and fixing centers.

- Interchangeable with old series

New escape release fitting

- No drilling necessary
- Reduced installation time
- No risk of damage to switch

New lid with captive screws

- Easier maintenance as screws stay with the lid when removed
- Wider screw torque tolerance
- Better alignment of lid when refitting
- Improved aesthetics at the gasket seal

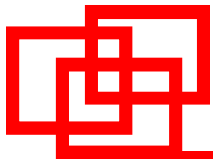

NEW LASER SCANNERS



Target Industries/Applications

- Robot cells
- Assembly cells
- Load / Unload stations
- AGV's

SafeZone Multizone Series B

- More Functionality than previous SafeZone Multizone
 - **4 switchable field sets in place of two field sets**
- Ideal for Stationary and Mobile applications
- Vertical or Horizontal mounting
- Configurable resolutions; 30mm, 40mm, 50mm, 70mm and 150mm
- Current SafeZone Multizone (Series A) will be discontinued when Series B is launched

In Stock

SafeZone Singlezone

- Single Field set (1 safety and 1 warning)
- 190 degrees scanning field
- Vertical or Horizontal mounting
- 4 meter safety field
- All other functionality of Multizone

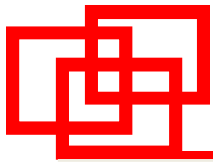

Area Access Detection

Vertical Mounting of the SafeZone requires the use of Contour as a reference

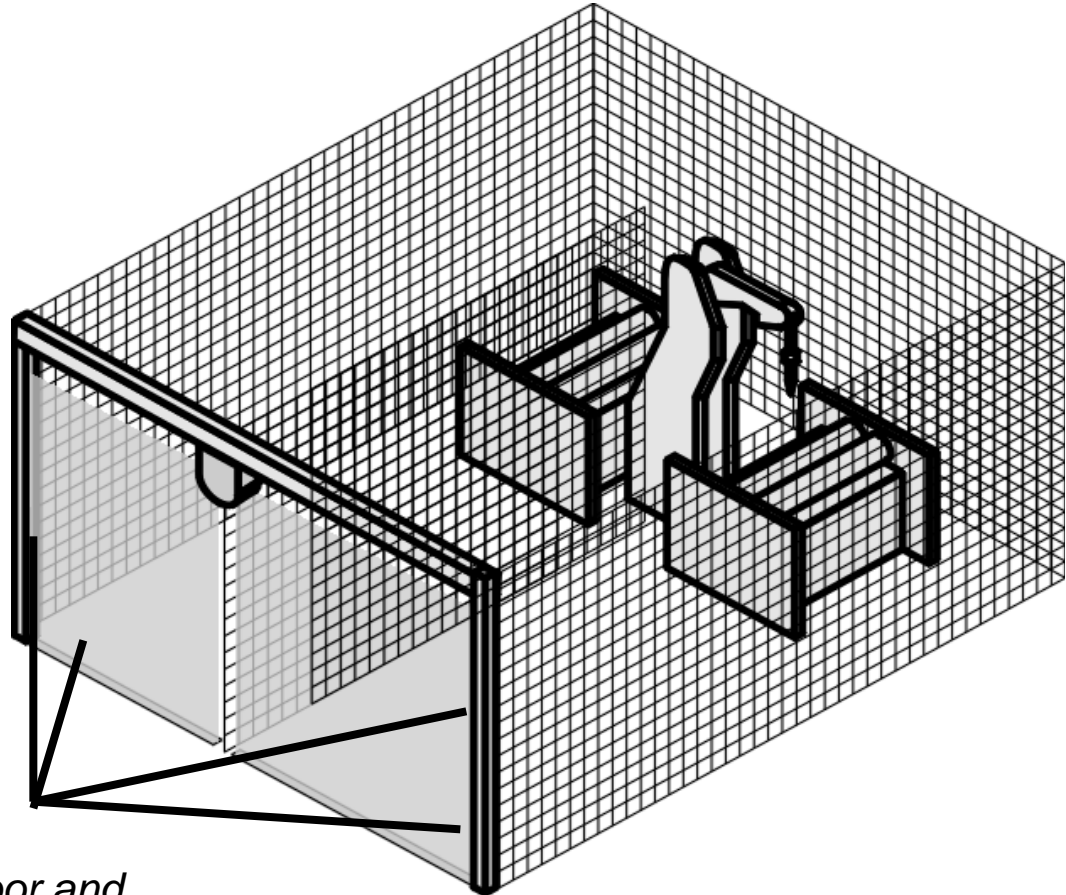

Contours on the floor and the side walls as reference

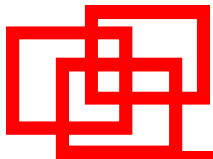

APPLICATION EXAMPLES

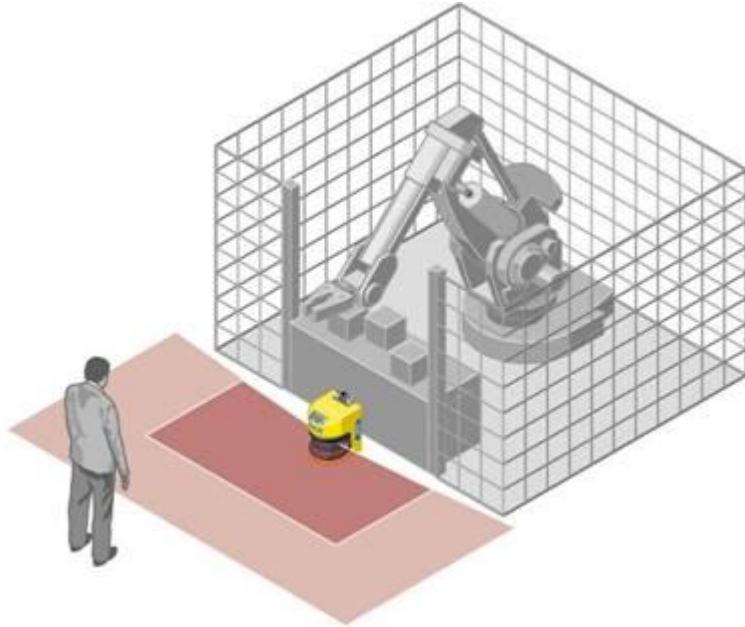

Stationary Horizontal Mounting

- 1 Warning Zone
- 1 Safety Zone

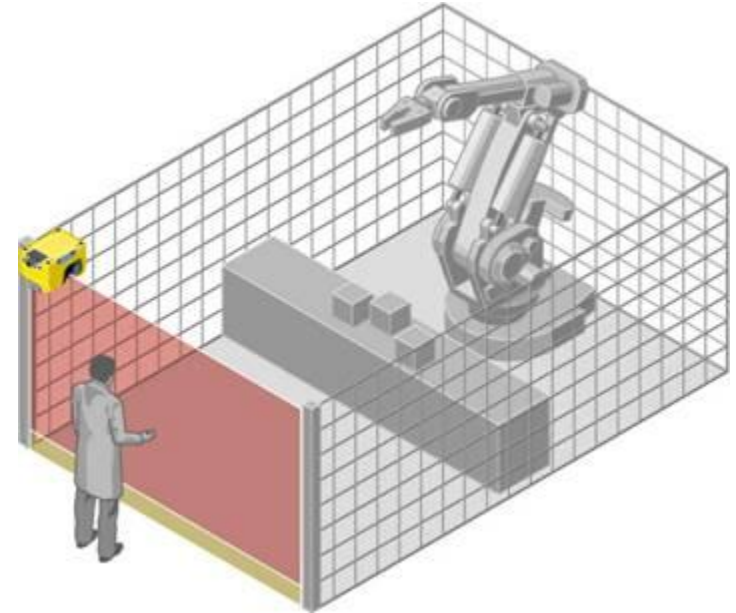

Access Guarding - Vertical Mounting

- No Warning Field
- 1 Safety Field
- Contour as Reference

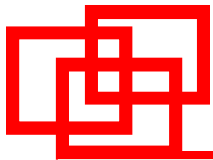

MULTIZONE APPLICATION EXAMPLES

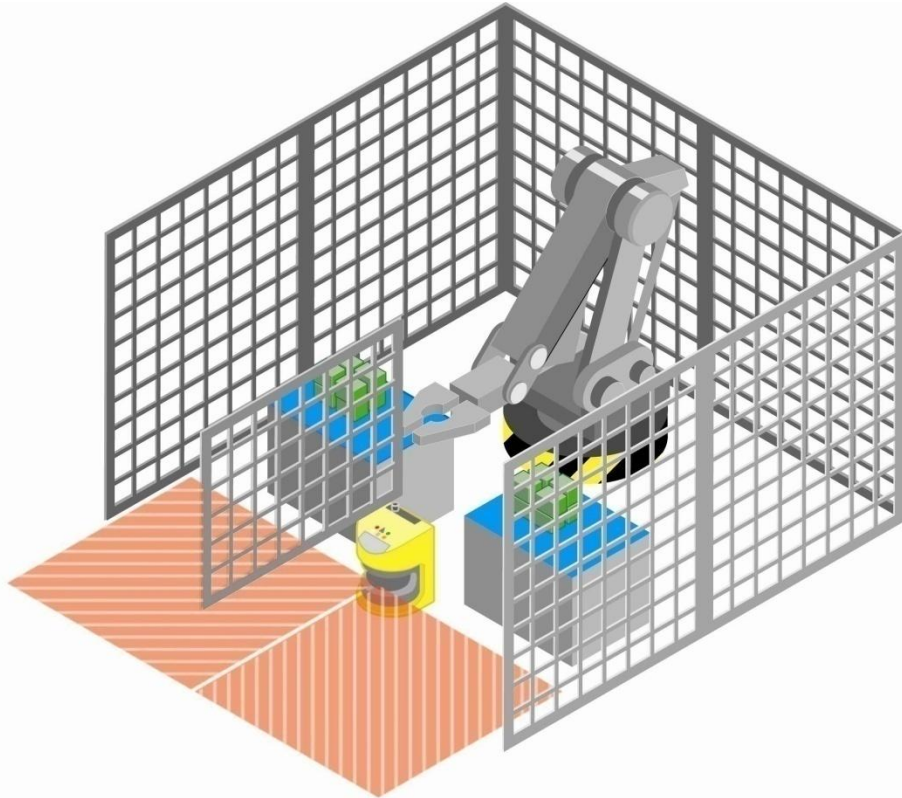

Stationary – Horizontal Guarding
• 2 Switchable field sets

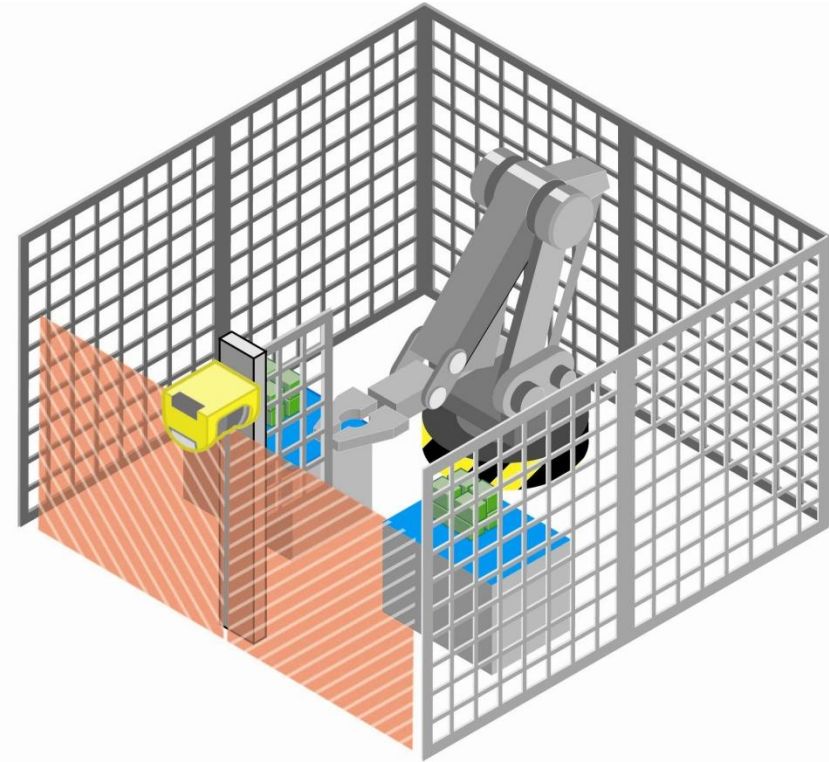

Access Guarding – Vertical Mounting
• 2 Switchable safety fields
• Contour as Reference is required for Vertical mounting

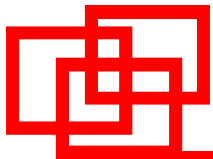

GUARDSHIELD WITH INTEGRATED LASER ALIGNMENT AND ARMORBLOCK IP67 SAFETY IO CONNECTIVITY

- Standard GuardShield, Cascadeable GuardShield and GuardShield PAC all will have a Laser Alignment System Integrated into each pair as well as the option for DeviceNet Safety Network Connectivity
- Integrated Laser will be available in 320mm to 1600mm heights
- Powered Class 2 visible laser beams located at the top and bottom of each light curtain pair.
- Simply touching the finger symbol on the face of the transmitter and receiver activates each alignment laser
- Each visible laser has a target opposite of it to facilitate optimal alignment
- GuardShield Standard, Cascadeable and PAC will be available with 5 pin M12 to allow connectivity to the RA ArmorBlock IP67 Safety IO block

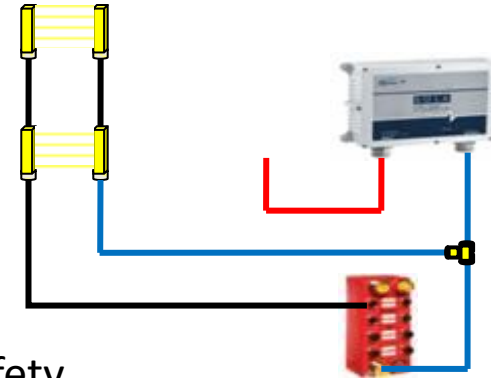

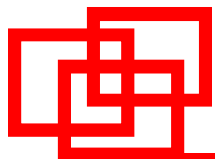

GUARDLOGIX SAFETY INTEGRATION

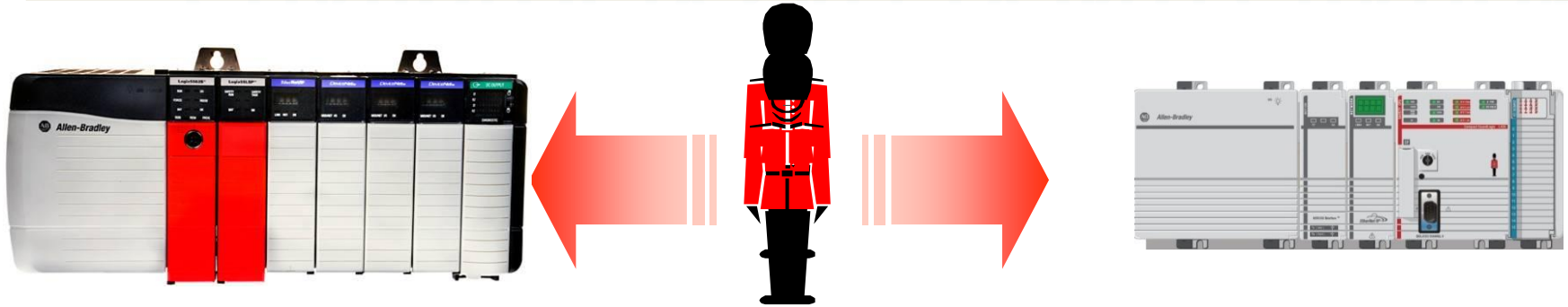

- **Logix Integrated Safety**

- Dual Processor Solution (1002 Architecture)

- 1002 is recognized as the best safety architecture

- SIL-3 Certification per IEC 61508

- ISO 13849 Performance Level e (Category 4)

- Programs with RSLogix5000

- Extensive suite of certified safety application instructions
 - Simplifies design, validation, maintenance
 - Dual Channel suite
 - Muting & Press Suite

- CIP Safety comm's for safety rated interlocking or safety I/O on Ethernet



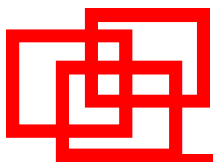

COMPACTLOGIX, COMPACT GUARDLOGIX L4X PACS

CompactLogix PAC easily handles simple to complex motion, simple to complex safety over multiple networks

- Advanced, high speed motion and communications via 1768 expansion



L43, L45 Standard PAC



L43S, L45S Integrated Safety PAC

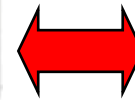

1769 local I/O

- Up to 8 modules on the local bank
- Maximum of 3 banks for a total of 30 modules
- DeviceNet with 1769-SDN scanner

Integrated Serial port

Network modules for EtherNet/IP & ControlNet

COS motion module



Modular design provides the flexibility to select the right modules to fit the application

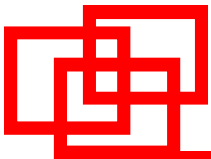

Questions??

Schaedler
yesco

ALLEN-BRADLEY • ROCKWELL SOFTWARE

Rockwell
Automation